

# Cyber-Physical Energy Systems

LECTURE 3

PRINCIPLES OF MODELING FOR CYBER-PHYSICAL SYSTEMS

INSTRUCTOR: MADHUR BEHL



## Tea Time In Britain

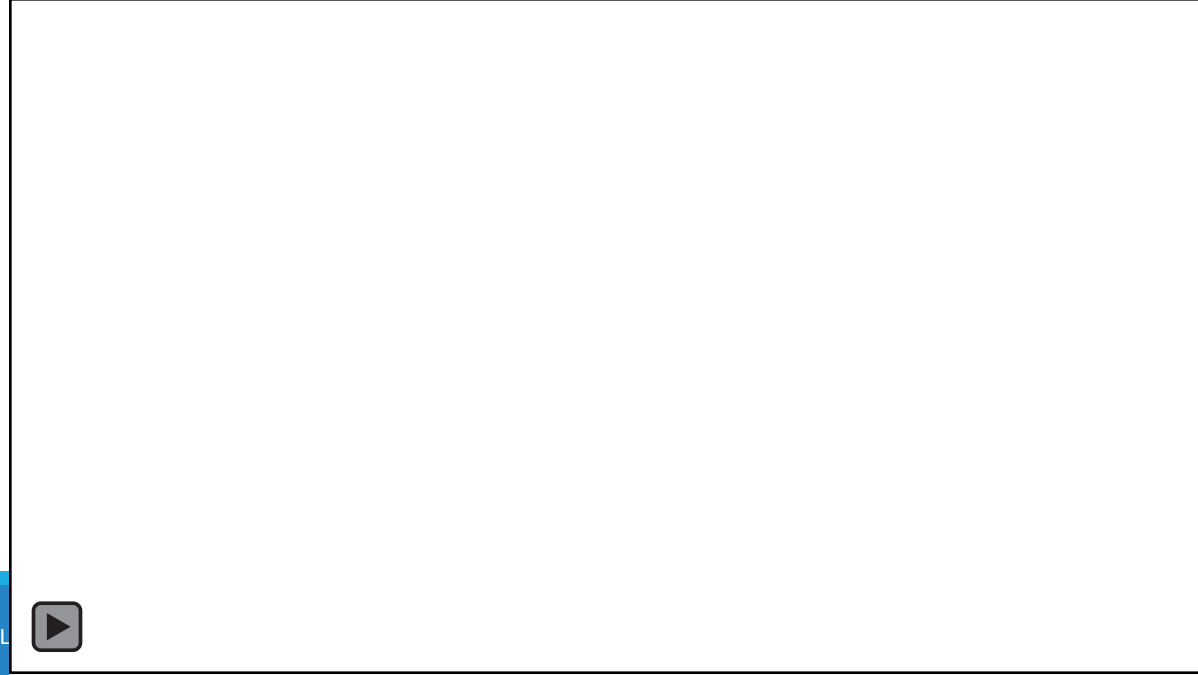

# Peaks occur during major sporting events



how many people watched the superbowl

All News Images Maps Videos More Settings Tools

About 2,060,000 results (0.75 seconds)

**111 million people**

More than **111 million people** watched Super Bowl LI. Feb 6, 2017

The Ad Age PRODUCTIONS logo, featuring a stylized figure in a dynamic pose.

Extreme Weather



World Cup



# Price Volatility: Summer peak

Nominal price: \$25/MWh

Peak Price: \$800/MWh

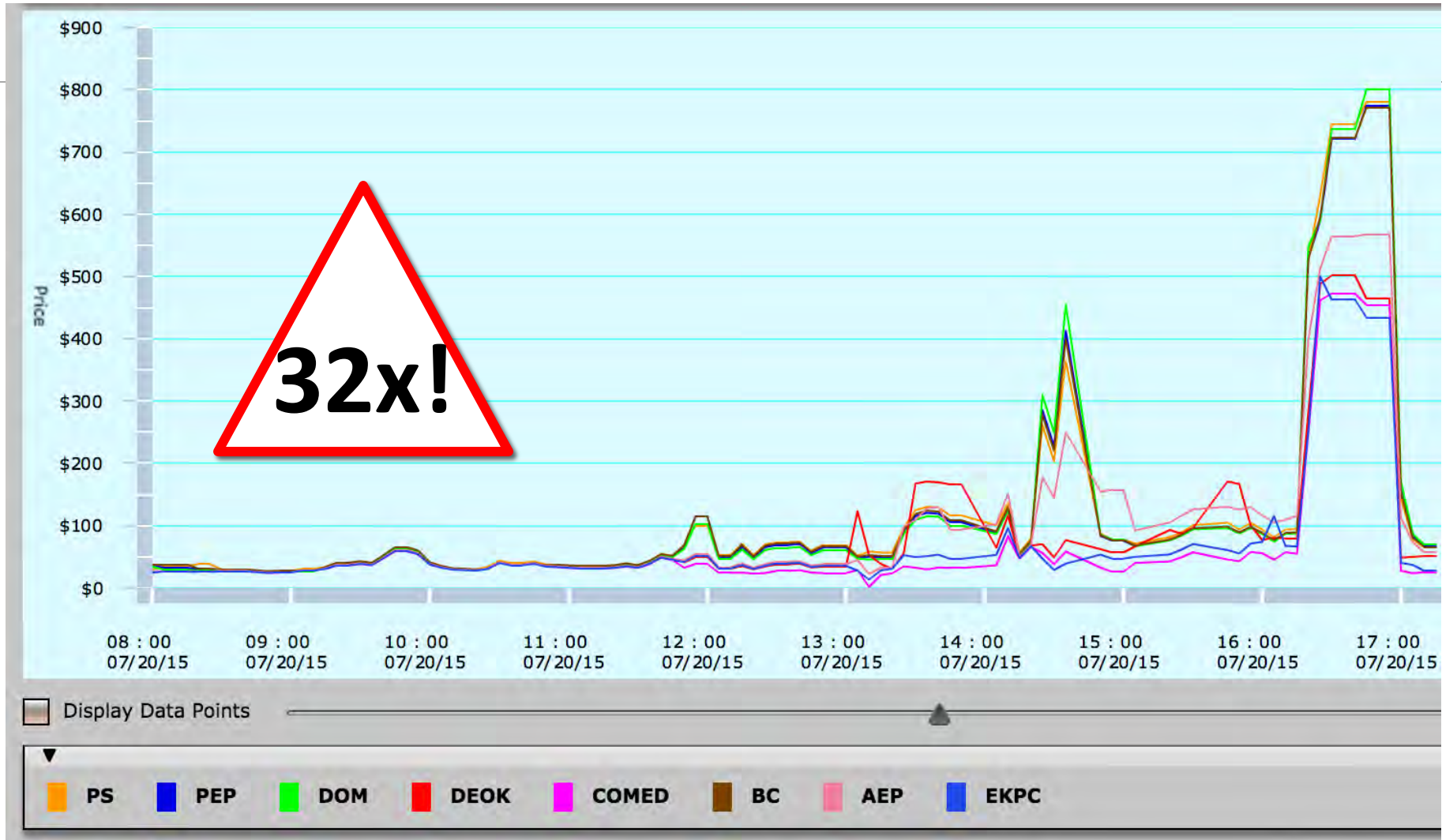

# Price volatility is the new normal

## PJM (ISO) Locational Marginal Prices (LMPs) example

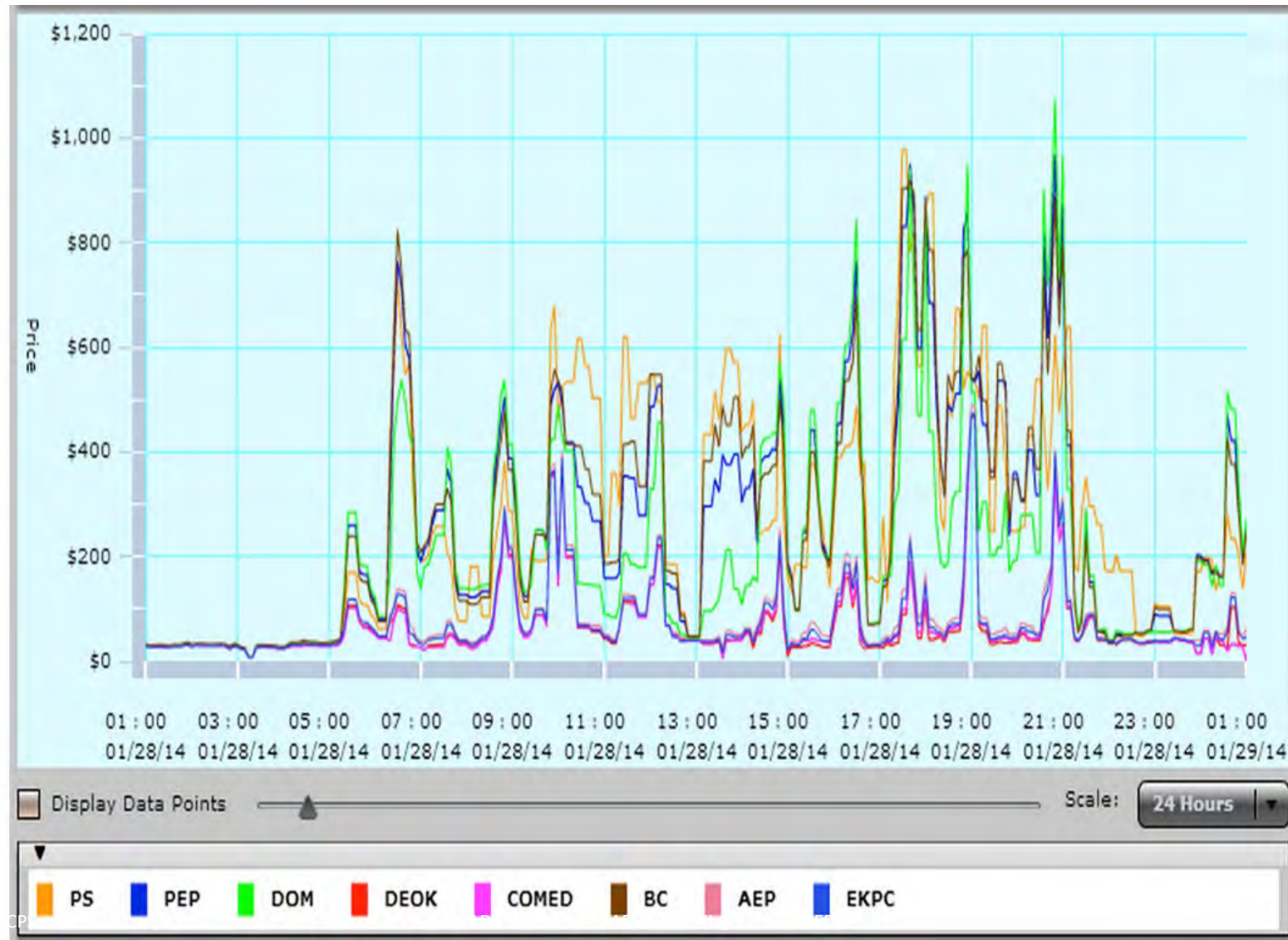

# Peak Demand is Expensive!

---

SURGE PRICING



---

Demand is off the charts! Fares have increased to get more Ubers on the road.

uberestimator.com

A dark blue semi-circle containing a white Uber car icon at the top and the text '2.2X' in large, light blue font in the center.

2.2X

# Peak Demand is Expensive!

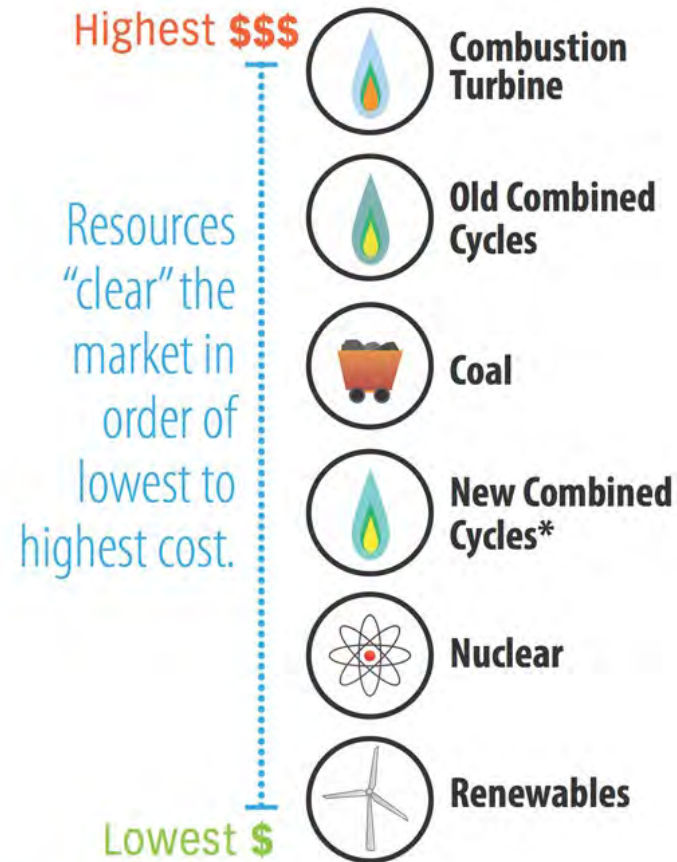
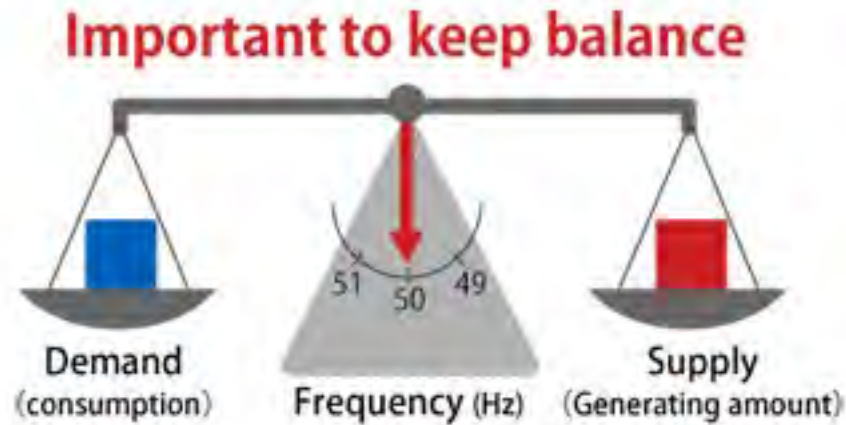

\*New combined cycles are more fuel efficient.



# Peak Demand is Expensive!

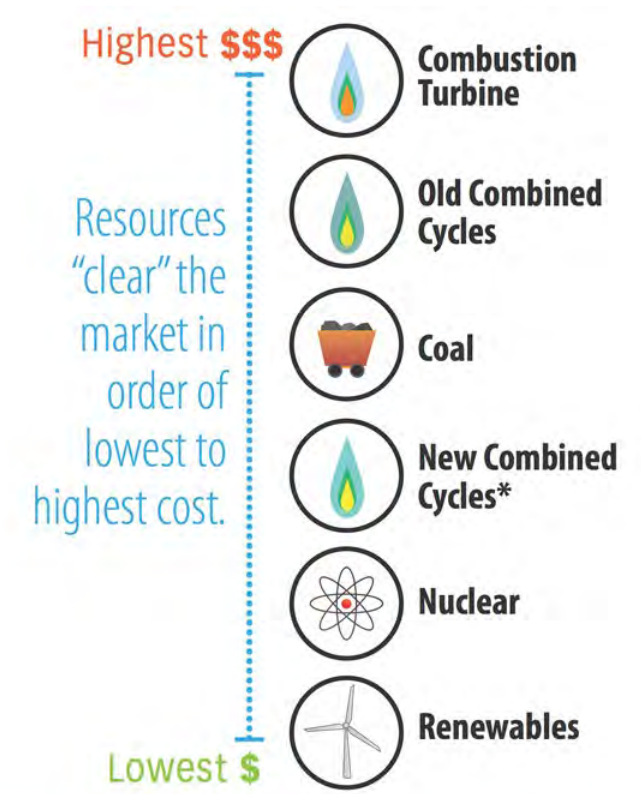
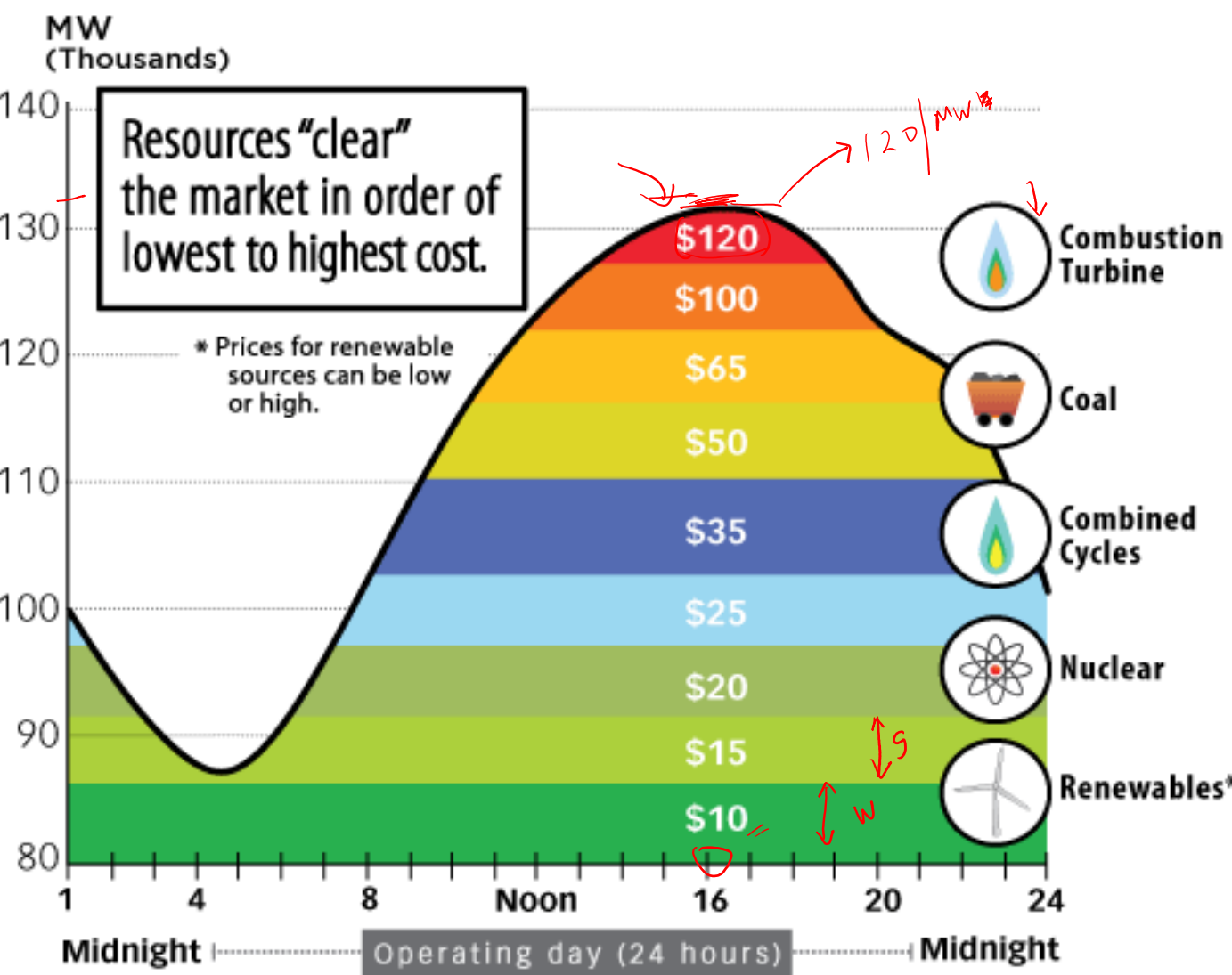

“All kilowatts are not created equally”

---

Older & Inefficient



Very Expensive

More Carbon



# Demand Response

---

-  Reliable
-  Clean
-  Cost-Effective

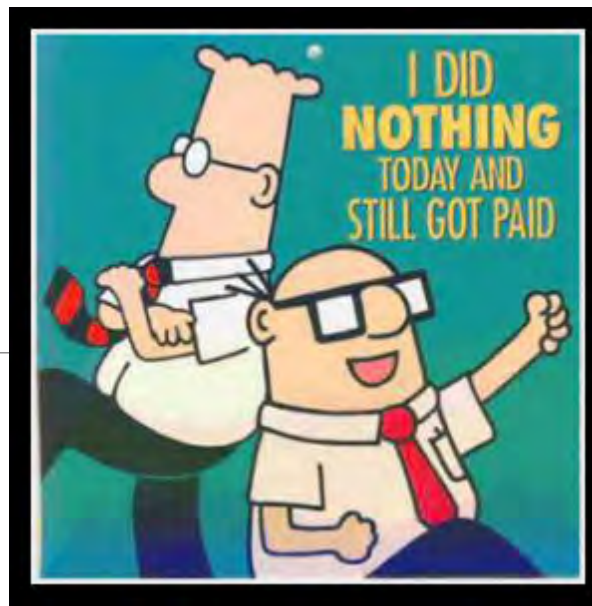

Imagine getting paid for doing nothing



## ~~Imagine getting paid for doing nothing~~

Greetings to you my friend,

I know this will come to you as a surprise because you do not know me.  
I am John Alison I work in Central Bank of Nigeria packaging and courier department.

I got your contact information from a search on the internet and I was inspired to seek your co-operation. I want to help me clear this consignment that is already in the Europe which I shipped through our CBN accredited agents. The content of the package is \$20,000,000.00 all in \$100 bills, but the courier company does not know that the consignment contains money.

All I want you to do now is to give me your mailing address, your private phone and fax number, and I believe that at the end of the day you will have 50% and 50% will be for me. My identity must not be revealed to anybody.

If this arrangement is okay by you, you can call

Phone: +234 8028776685  
Email: [john\\_alison444@yahoo.com](mailto:john_alison444@yahoo.com)

---

Imagine getting paid, or otherwise compensated, **for not using electricity during peak hours!**



# A Demand Response Event

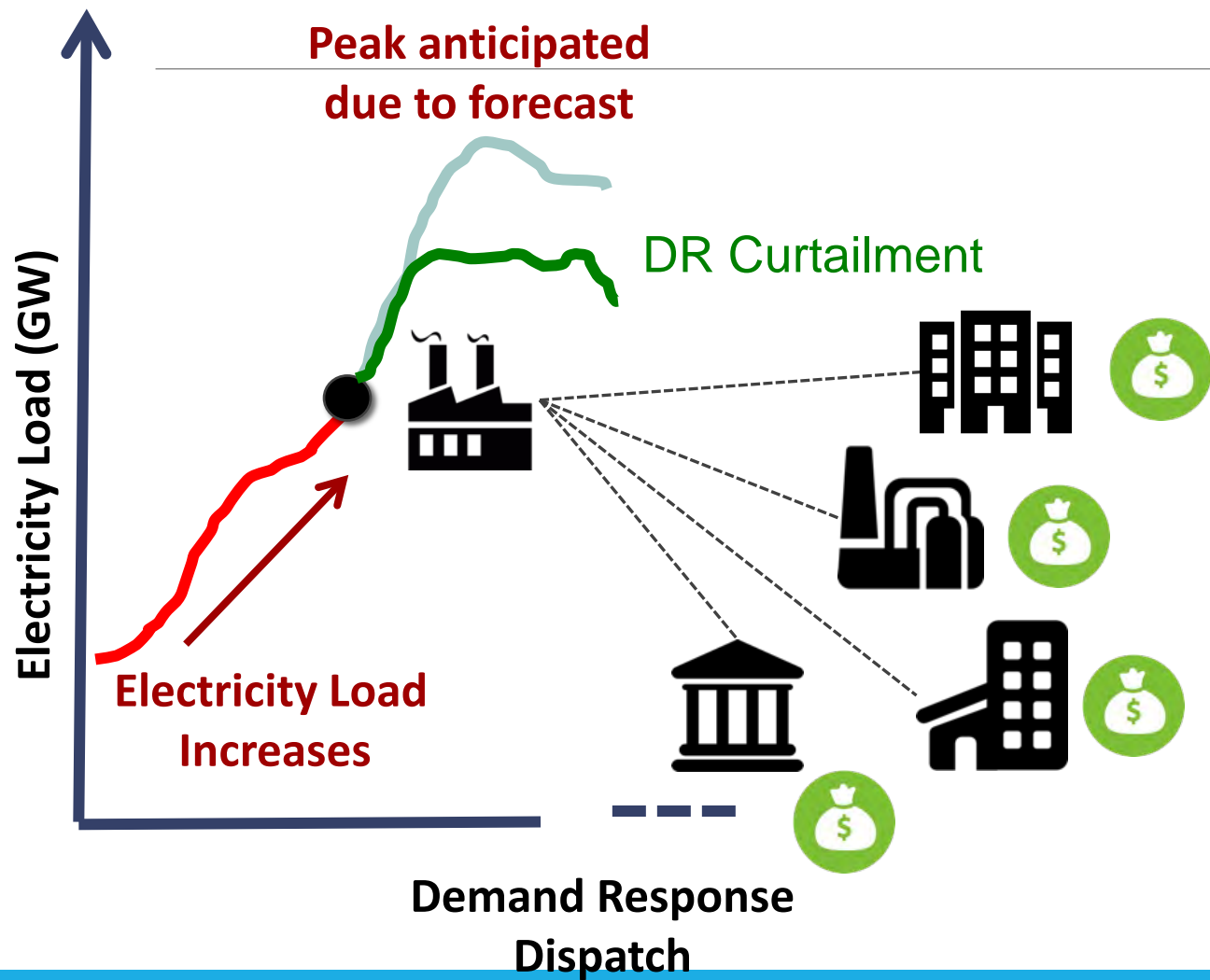

# Demand Response – Looks familiar



**VOLUNTEERS ARE NEEDED** NO THANKS

NYC-KENNEDY, NY ▶ LOS ANGELES, CA 29 JUN 2014

Do you want to be added to the volunteer list for your flight departing from NYC-Kennedy, NY to Los Angeles, CA? We are seeking volunteers willing to take a different flight in exchange for a travel voucher redeemable within 1 year on delta.com.  
Your existing itinerary will not be changed until you review alternate flights at the departure gate.

Select the dollar value of the travel voucher you would accept as compensation for volunteering your seat.  
**Note:** If your seat is needed, you will receive a travel voucher for this amount.

AMOUNT:

**Helpful Tip:** Delta accepts the lowest bids first. SUBMIT BID



Fixed Strategy 1

Fixed Strategy 2

Fixed Strategy 3

Fixed Strategy 4

Fixed Strategy 5





Q) *If you don't know what's going to happen when you change a set-point.  
How do you even know the change is worth making ?*

Q) *What is the best change that you can make right now ?*

Model-based predictive control (MPC)

What kind of models ?

# The control problem in buildings

## Integrated control of:

- Heating
- Cooling
- Ventilation
- Lighting
- Blinds



# Model Predictive Control (MPC)

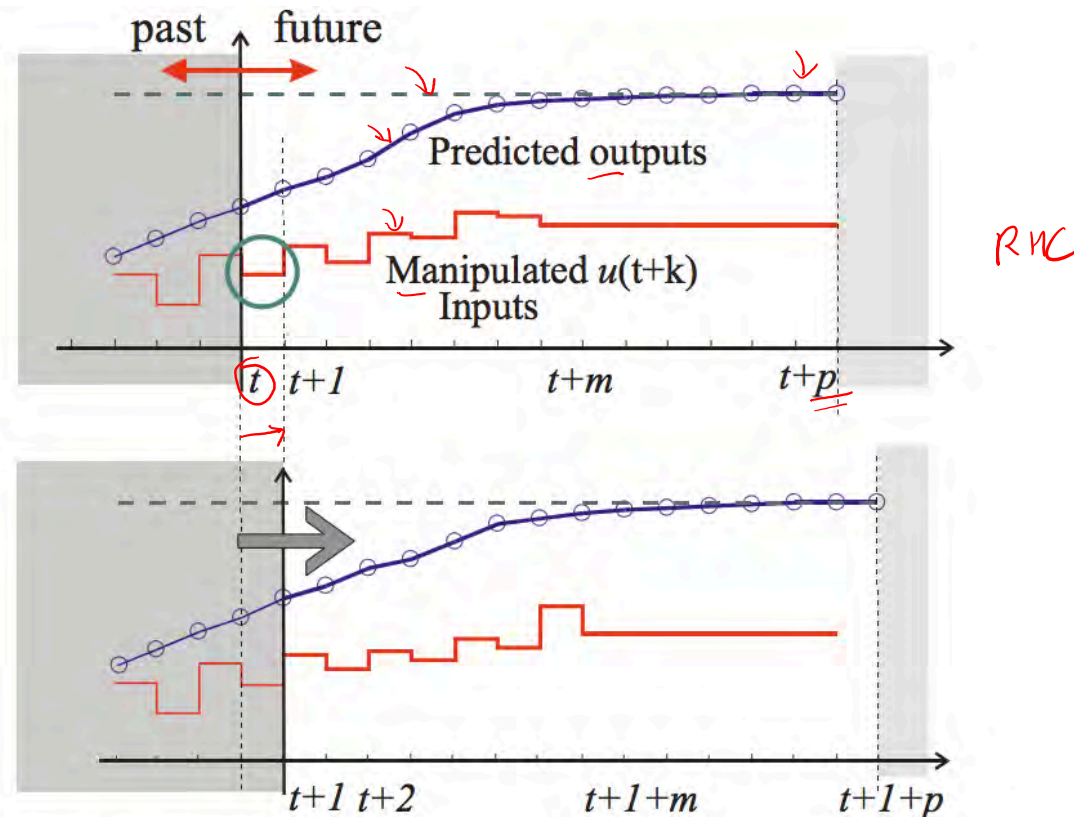

- Determine state  $x(t)$
- Determine optimal sequence of inputs over horizon
- Implement first input  $u(t)$
- Wait for next sampling time;  $t := t + 1$

# Generation, Transmission, Distribution: Supply-side

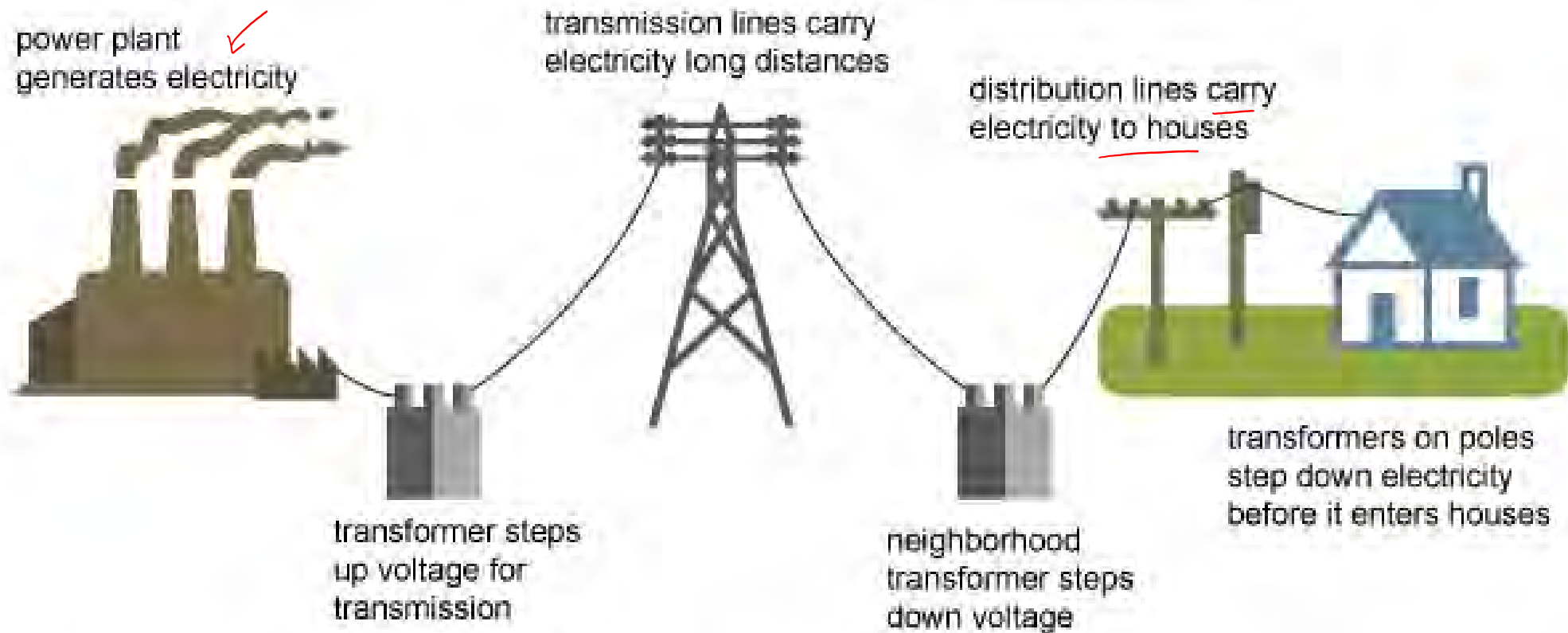

Source: Adapted from National Energy Education Development Project (public domain)

# Modeling the grid dynamics ?



# Modeling the grid dynamics ? Not in this course.

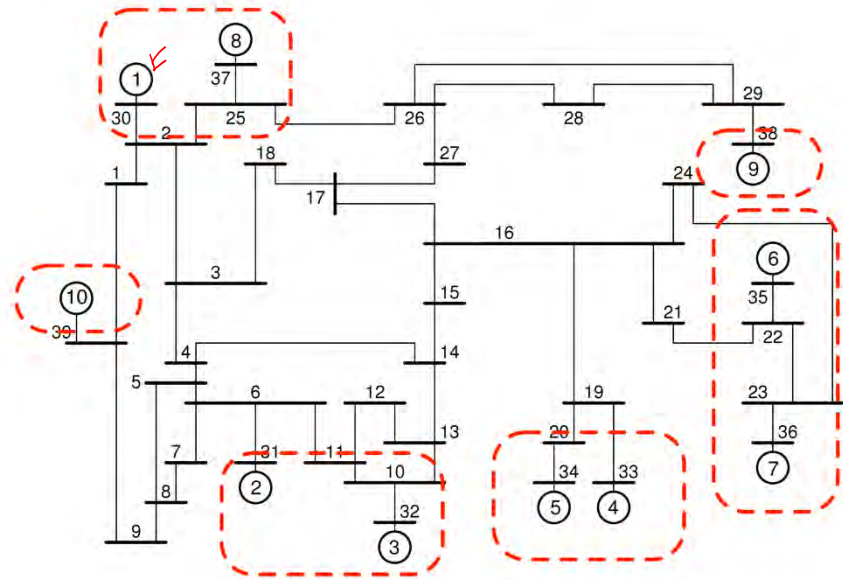

## IEEE 39 New England Power Grid Model

- 39 transmission buses
- 10 generators

linearized dynamics:  $\dot{x}(t) = Ax(t) + B_1 d(t) + B_2 u(t)$

objective function:  $J = \lim_{t \rightarrow \infty} \mathcal{E} \left( \theta^T(t) Q_\theta \theta(t) + \dot{\theta}^T(t) Q_{\dot{\theta}} \dot{\theta}(t) + u^T(t) R u(t) + \gamma \sum_{i,j} w_{ij} |F_{ij}| \right)$

memoryless controller:  $u = -F x(t)$

# Electricity consumption Buildings: Demand-side

---

Commercial, Industrial & Institutional (C/I/I)

Residential





# Why Buildings ?

**40%**

Portion of global energy use

**70%**

Portion of electricity consumption in  
the United States

**1/3**

Portion of global total CO<sub>2</sub> emissions

62%

Electricity use due to cooling,  
lighting and ventilation

Portion of natural gas use  
dedicated to space heating

86%

FIGURE 1: Office buildings energy consumption by end use in the U.S.  
Data from the U.S. Energy Information Administration show that cooling, lighting, and ventilation account for 62 percent of electricity use (A), and space heating dominates natural gas use at 86 percent (B).

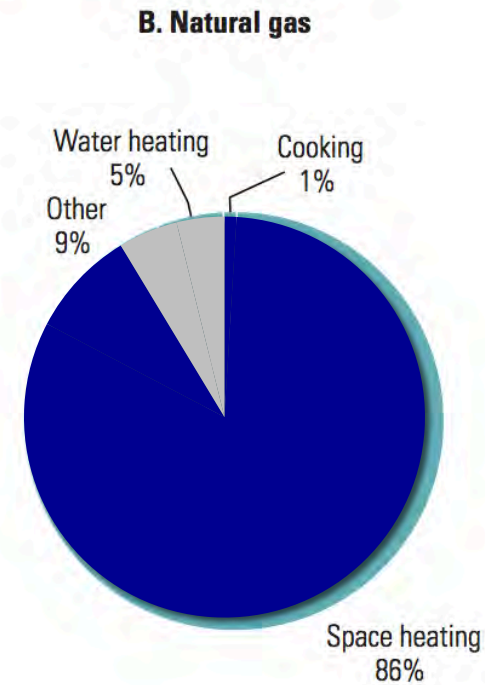
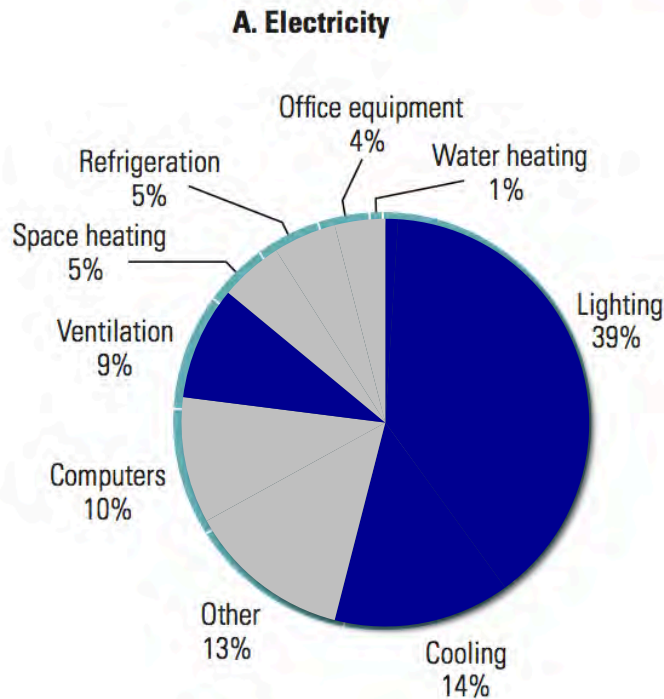

Note: Insufficient data were available for electric consumption of Cooking equipment; sum may not total 100% due to rounding.

© E Source; data from the U.S. Energy Information Administration

# How are building models obtained today ?



**White Box**

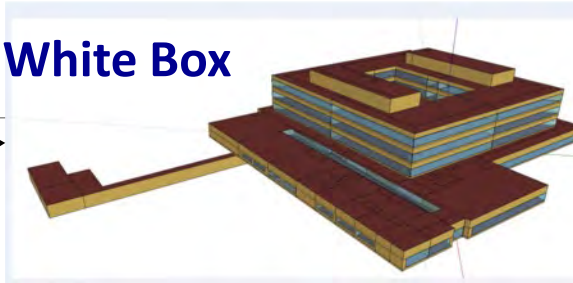

**Grey Box**

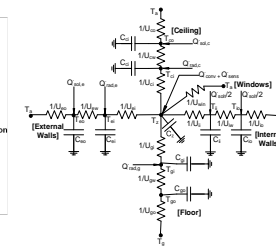
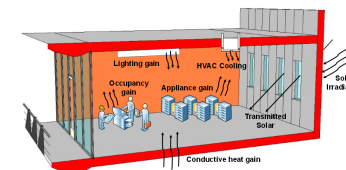

**Black Box**

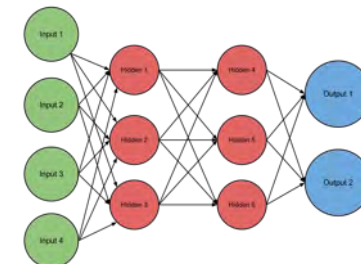

# How are building models obtained today ?



White Box

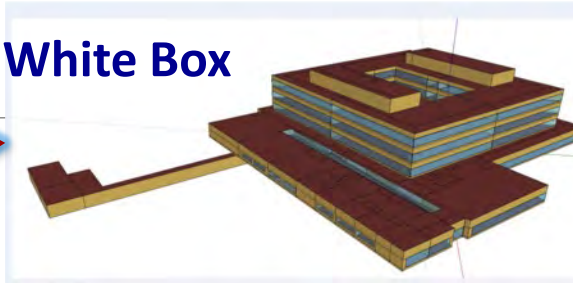

Grey Box

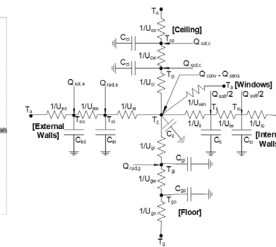
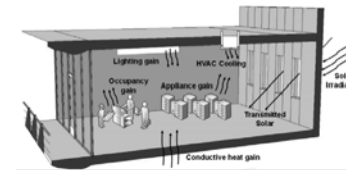

Black Box

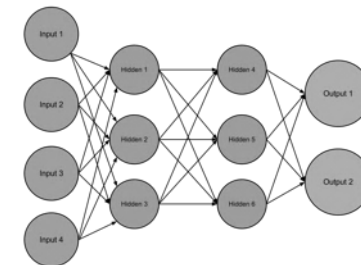

# White-Box Modeling



Not always

available

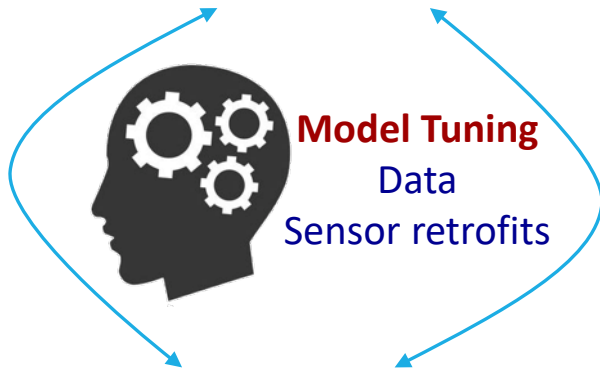
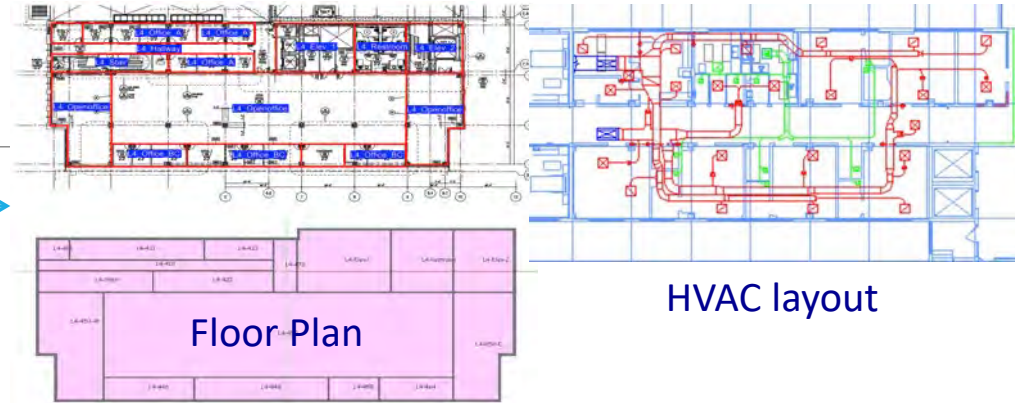

Set parameters  
Floor by floor  
Zone by zone  
Wall by wall  
Layer by layer  
Equipment by equipment  
**Transfer geometry**

Guess nominal  
parameter  
values



Hire building  
modeling  
experts

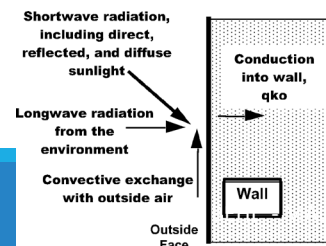
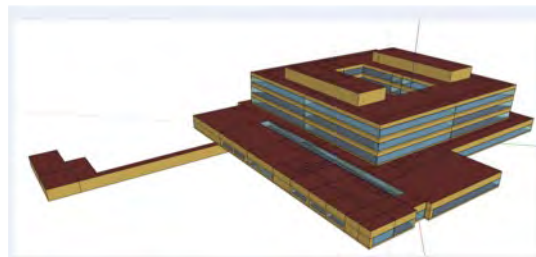

First principles based building energy simulation

# White-Box Modeling

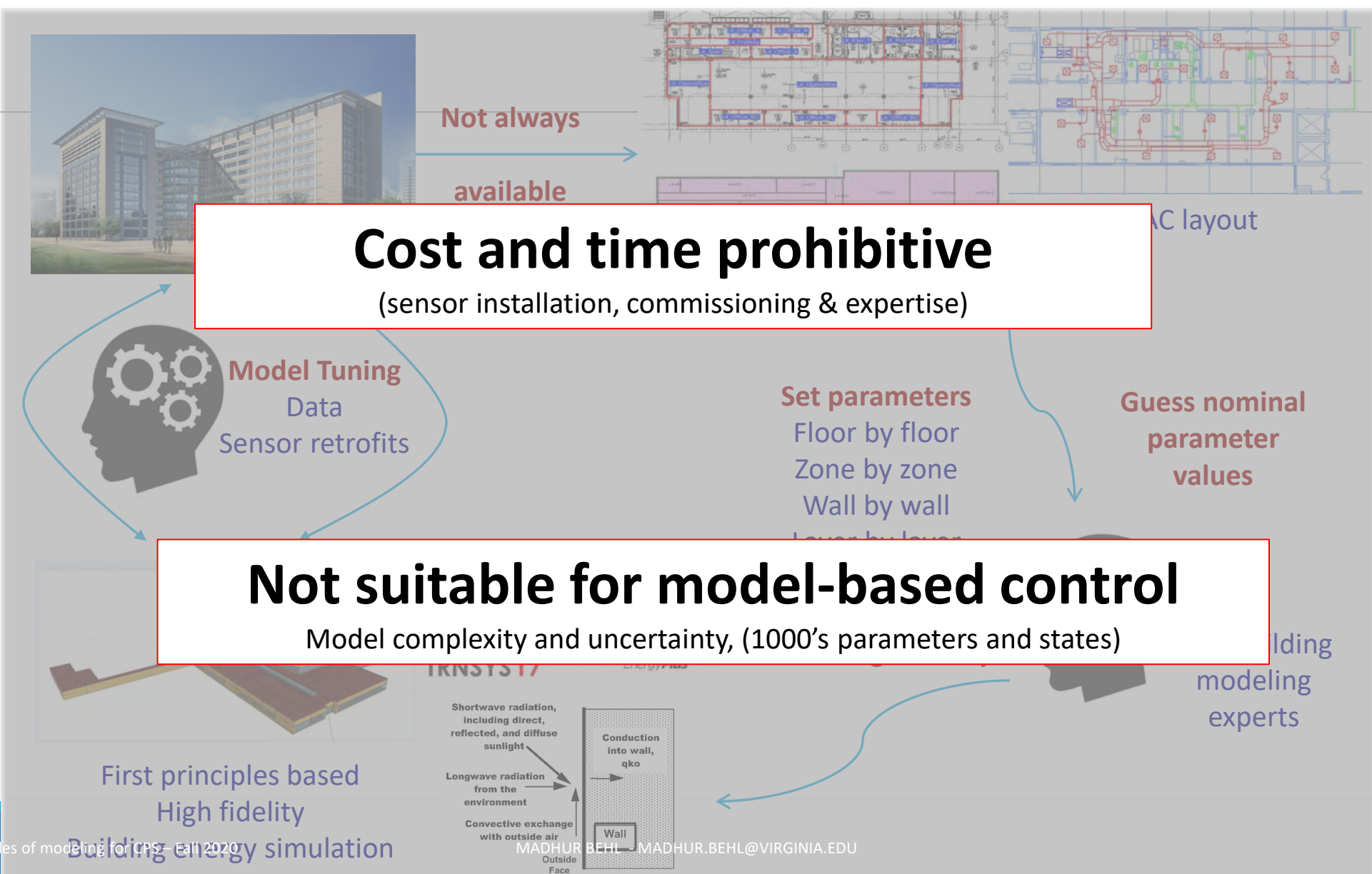

# How are building models obtained today ?

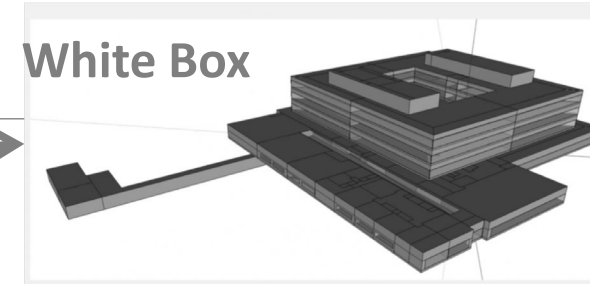

## Grey Box

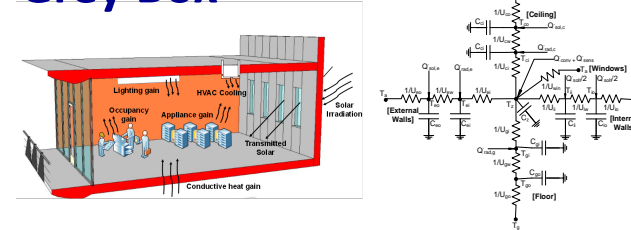

## Black Box

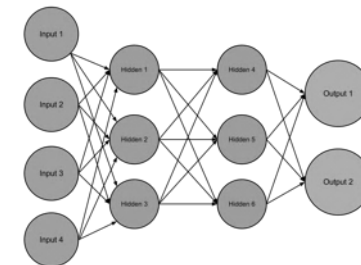

# Grey-Box [Inverse] Modeling



Not always

available

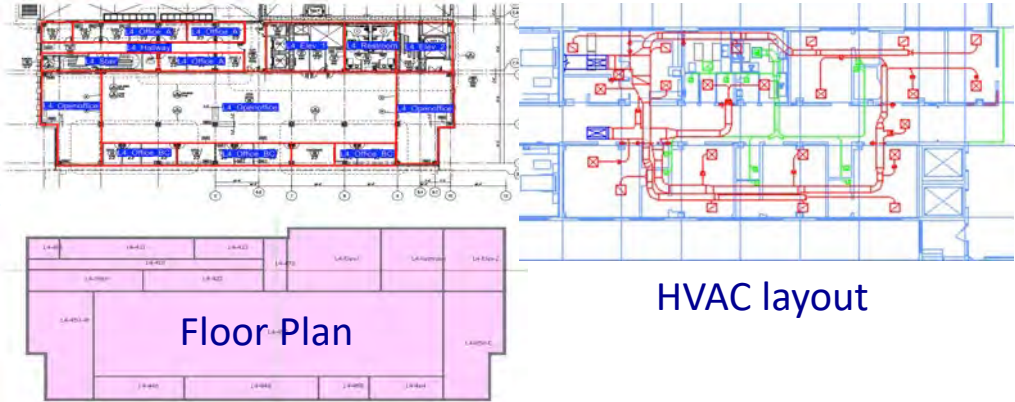

HVAC layout

Floor Plan



Parameter Estimation

Data

Sensor retrofits

Set parameters

- Floor by floor
- Zone by zone
- Wall by wall
- Layer by layer
- Equipment by equipment

Guess nominal parameter values



Hire building modeling experts

$$C_{co}\dot{T}_{co}(t) = U_{co}(T_a(t) - T_{co}(t)) + U_{cw}(T_{ci}(t) - T_{co}(t)) + \dot{Q}_{sol,c}(t)$$

$$C_{ci}\dot{T}_{ci}(t) = U_{cw}(T_{co}(t) - T_{ci}(t)) + U_{ex}(T_z(t) - T_{ci}(t)) + \dot{Q}_{rad,c}(t)$$

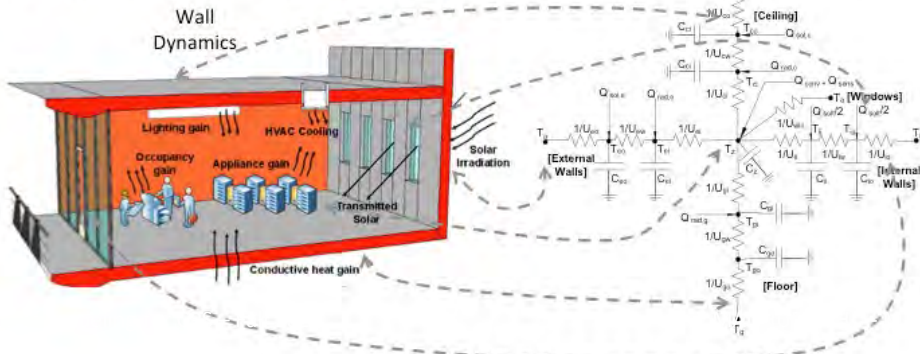

Transfer geometry

Lumped Parameter 'RC' model



# Grey-Box Modeling: 'RC' networks

Discrete-Time State Space Model:

(parameterized by  $\theta$ )

States (**All node temperatures**):

$$x = [T_{eo}, T_{ei}, T_{co}, T_{ci}, T_{go}, T_{gi}, T_{io}, T_{ii}, T_z]^T$$

Inputs (**Disturbances and Control**):

$$u = [T_a, T_g, T_i, Q_{sole}, Q_{solc}, Q_{rade}, Q_{radc}, Q_{radg}, Q_{solt}, Q_{conv}, Q_{sens}]^T$$

$$x(k+1) = \hat{A}_\theta x(k) + \hat{B}_\theta u(k)$$

$$y(k) = \hat{C}_\theta x(k) + \hat{D}_\theta u(k)$$

Parameter Estimation:

Least Squares Error

$$\theta^* = \arg \min_{\theta_l \leq \theta \leq \theta_u} \sum_{k=1}^N (T_{z_m}(k) - T_{z_\theta}(k))^2$$

subject to  $\theta_l \leq \theta \leq \theta_u$

## LIST OF PARAMETERS

$U_{*o}$	convection coefficient between the wall and outside air
$U_{*w}$	conduction coefficient of the wall
$U_{*i}$	convection coefficient between the wall and zone air
$U_{win}$	conduction coefficient of the window
$C_{**}$	thermal capacitance of the wall
$C_z$	thermal capacity of zone $z_i$

*g*: floor; *e*: external wall; *c*: ceiling; *i*: internal wall

# Heating, Ventilation, & Air Conditioning

---

# HVAC



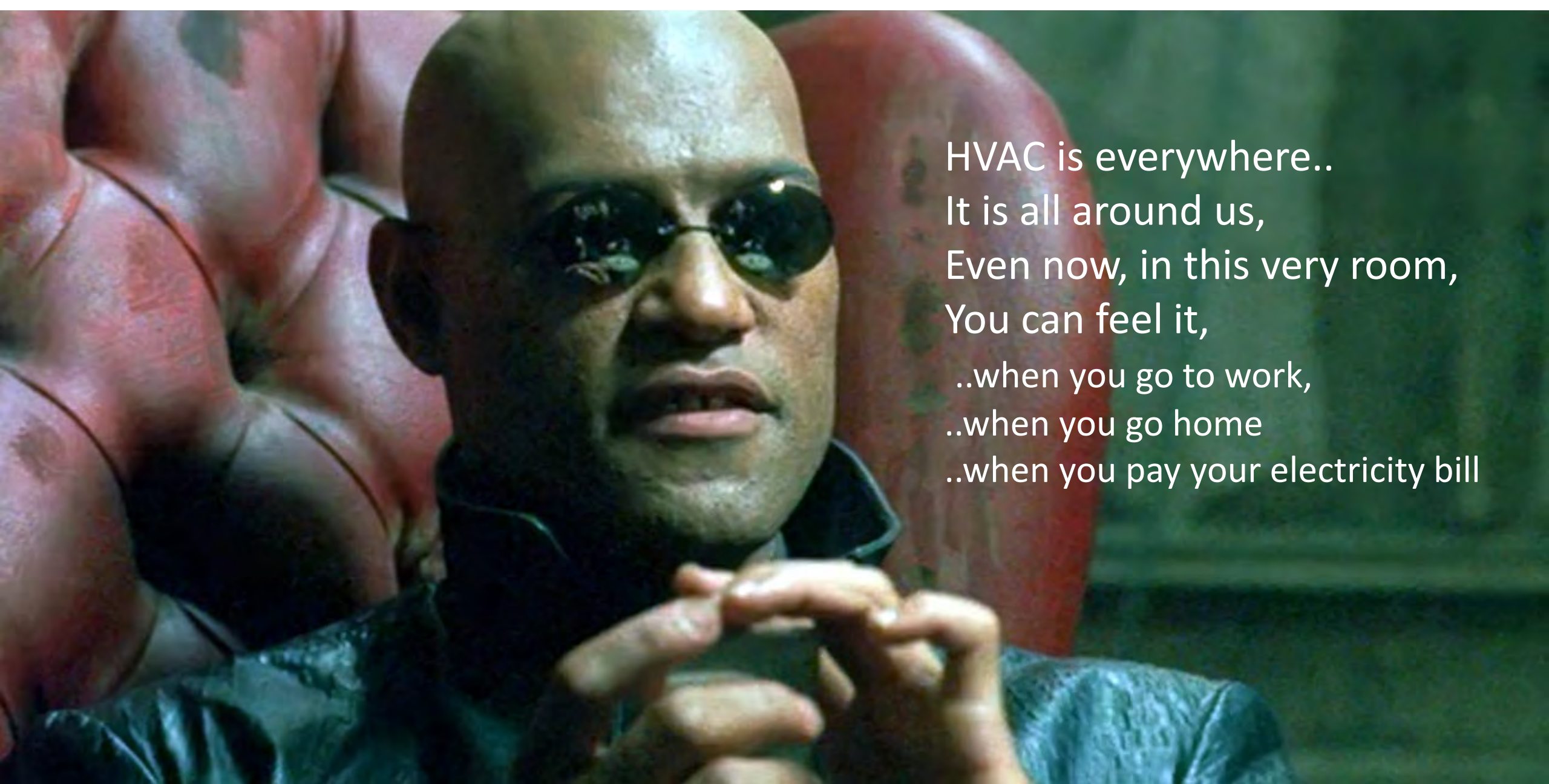

HVAC is everywhere..  
It is all around us,  
Even now, in this very room,  
You can feel it,  
..when you go to work,  
..when you go home  
..when you pay your electricity bill

# Its all about comfort..

---

●	<b>Temperature</b>	<i>68°F (20°C) and 75°F (25°C)</i>
●	<b>Humidity</b>	<i>30% relative humidity (RH) and 60% RH</i>
●	<b>Pressure</b>	<i>A slightly positive pressure to reduce outside air infiltration.</i>
●	<b>Ventilation</b>	<i>Rooms typically have several complete air changes per hour</i>

# Components of HVAC System

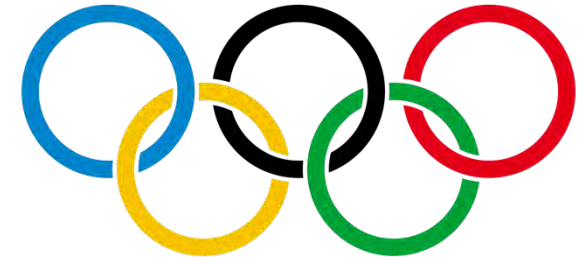

5 system loops..

---

## The Five System Loops

---

 **Airside**

 **Heat rejection**

 **Chilled water**

 **Controls**

 **Refrigeration**

# Air handling systems

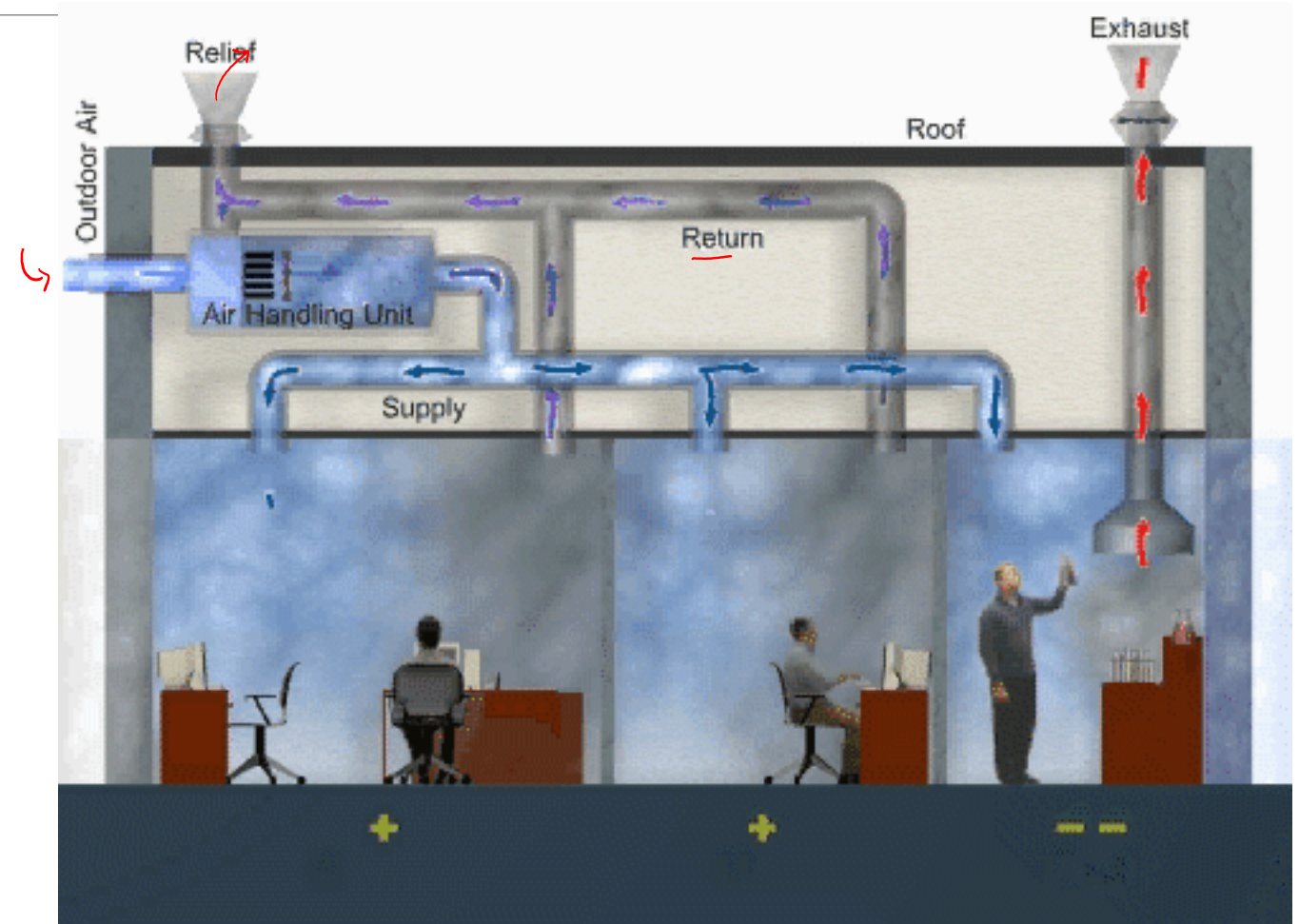
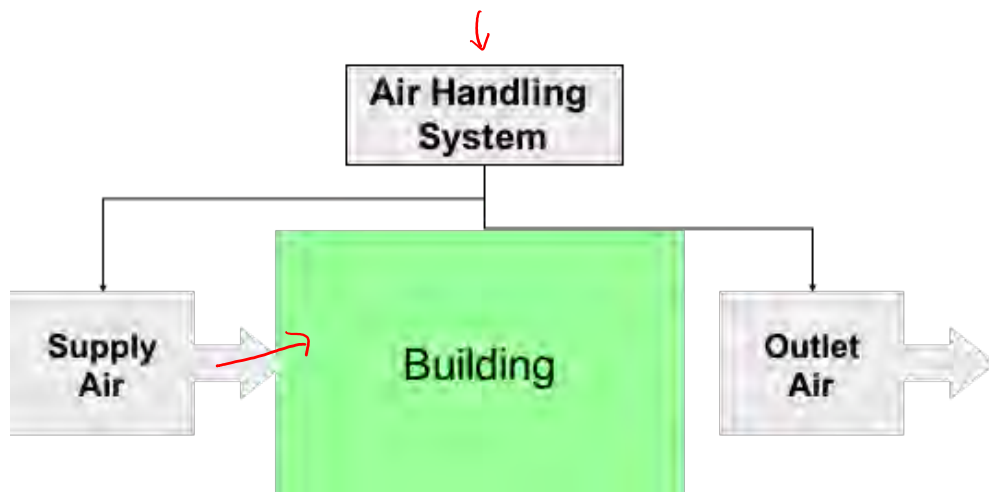

# Air handling systems

---

- Delivers air to zones
- Heats and cools air
- Often integrates ventilation

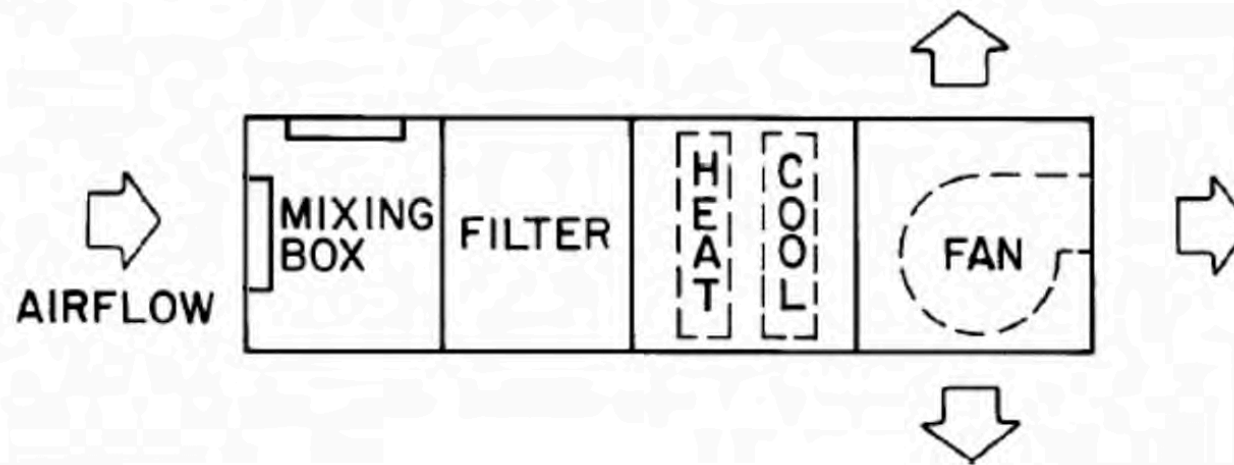

# Air handling system

## Air types

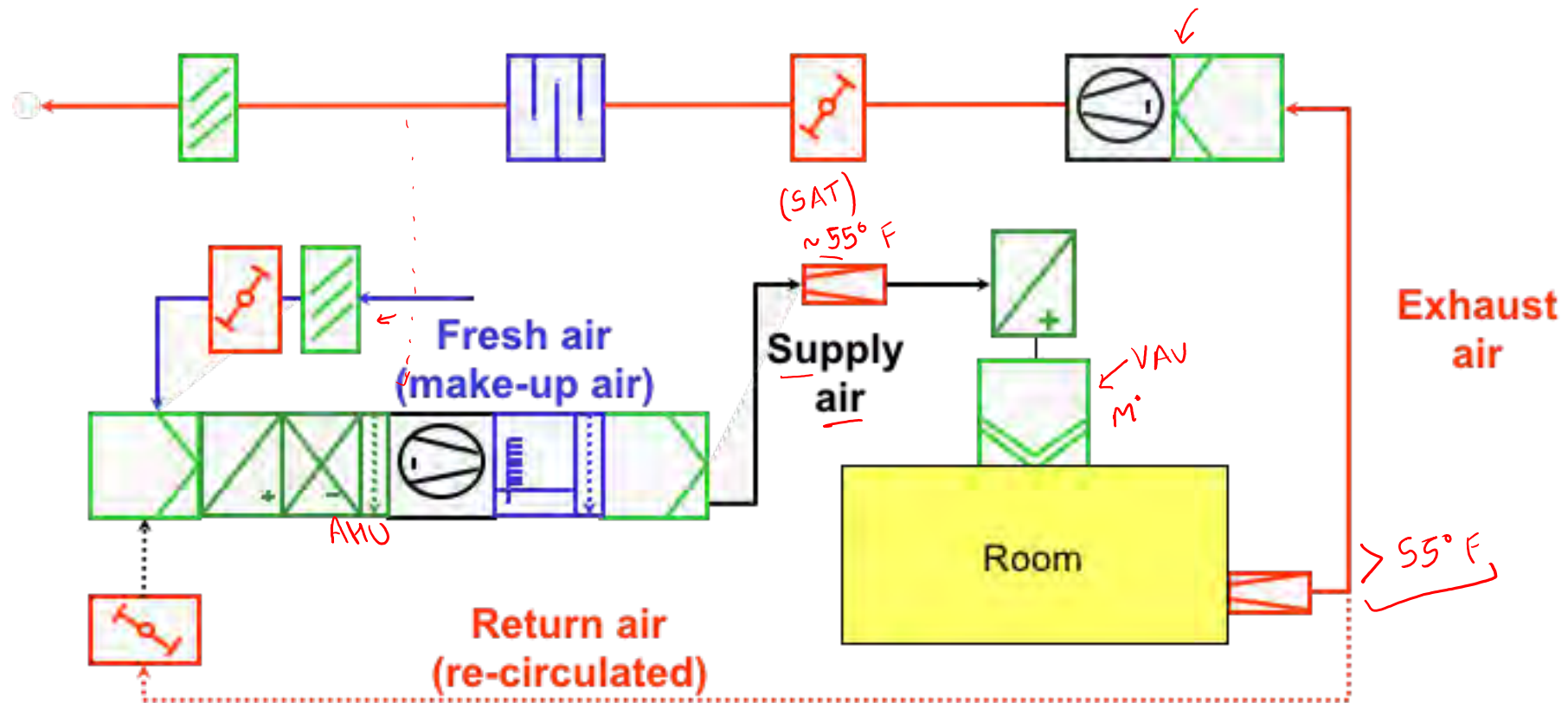



# Air handling unit

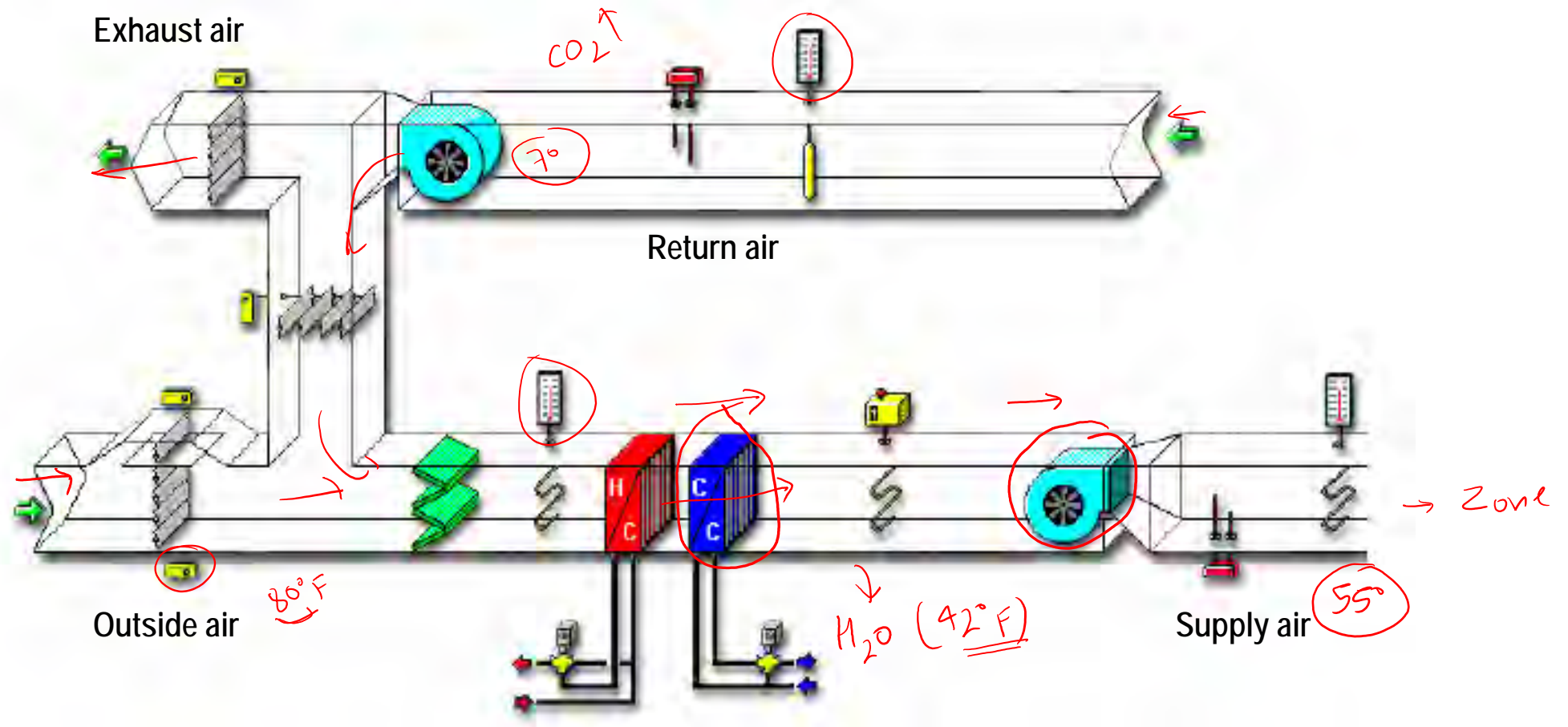

# Air handling unit

---



# Air terminals: Constant Air Volume (CAV)

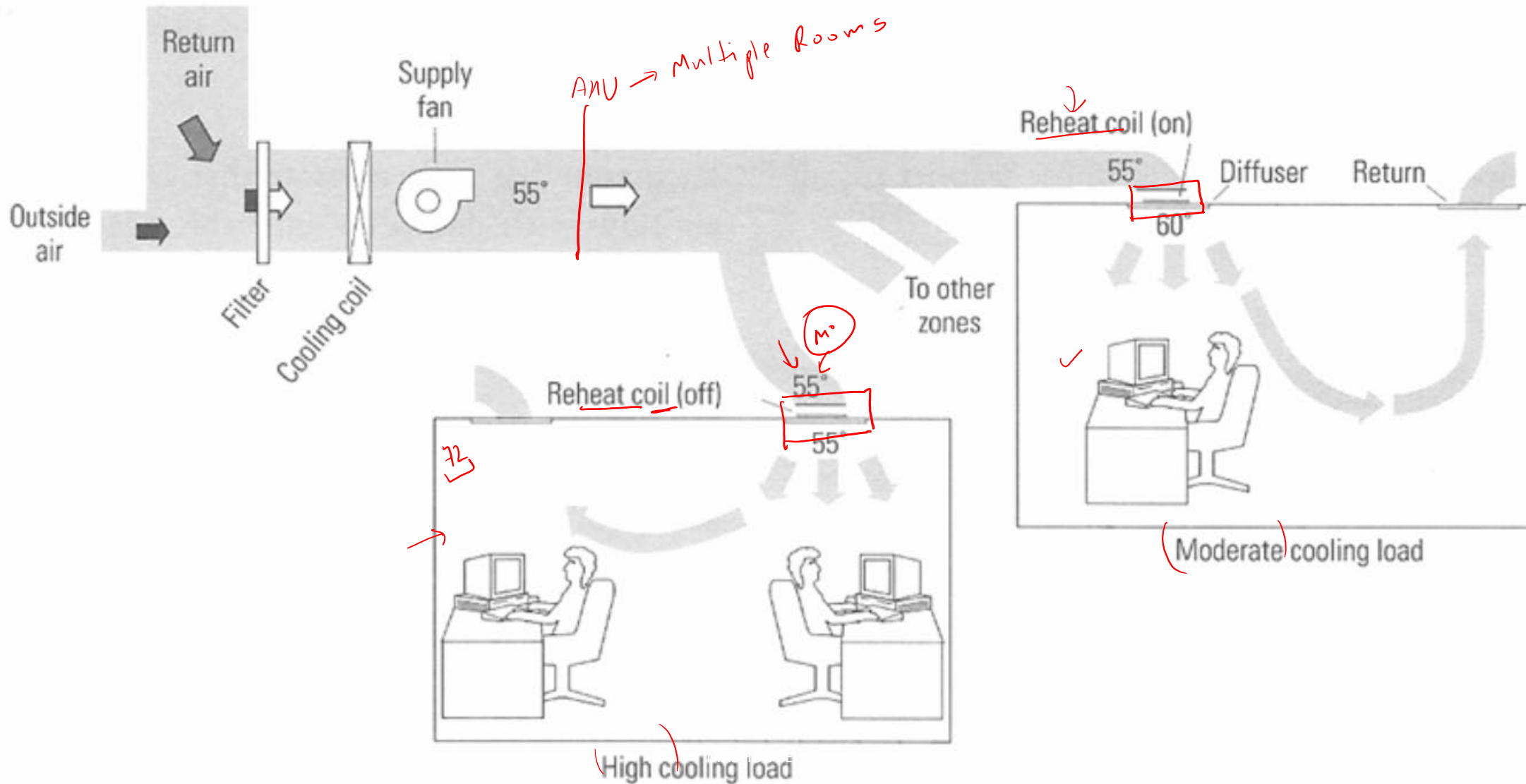

# Air terminals: Variable Air Volume (VAV)

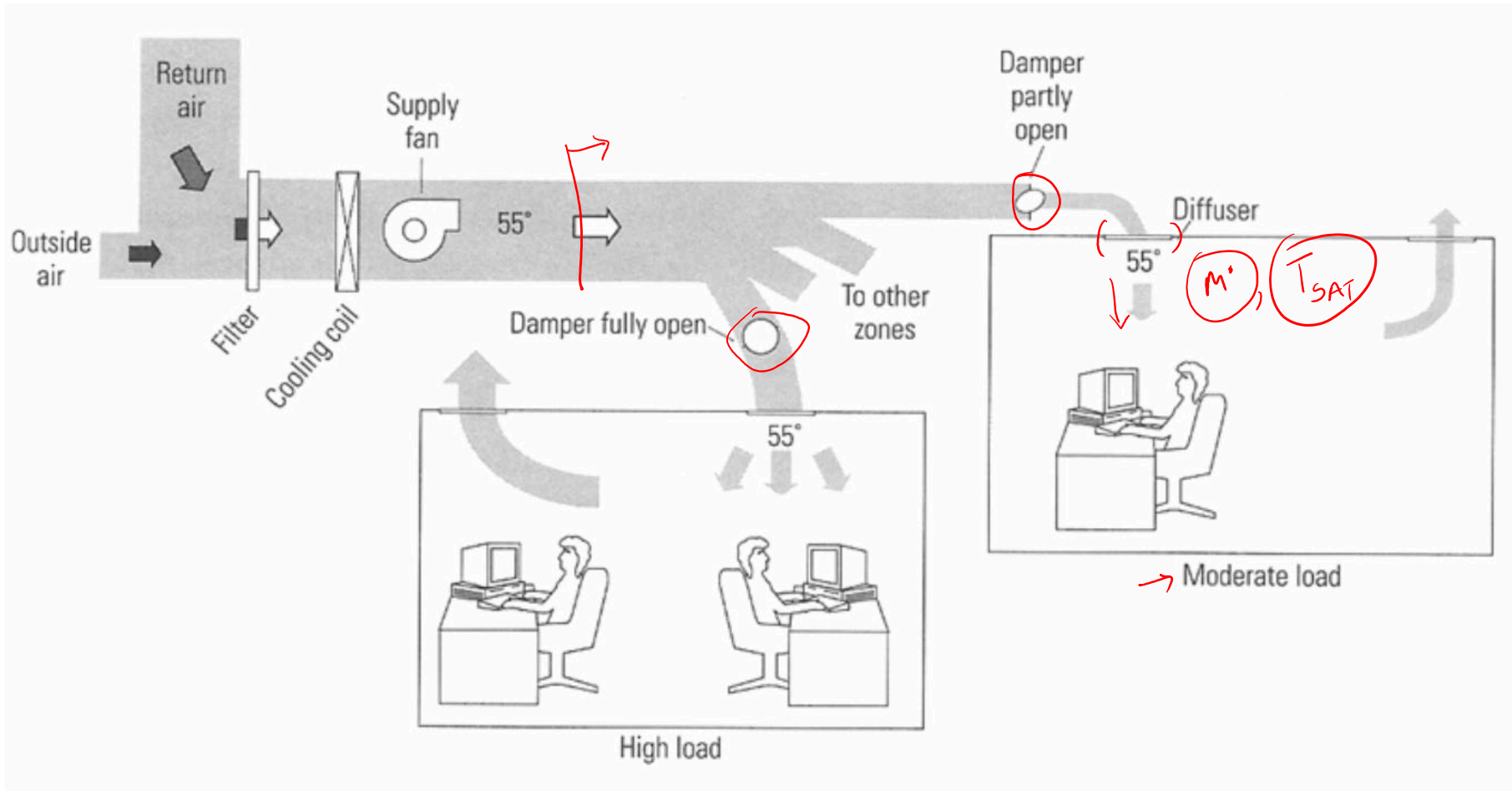

IF temperature too high

First reduce reheat till fully closed  
Then increase air volume

IF temperature too low

First reduce air volume till minimum  
Then start reheat

# Ceiling plenum return

The plenum is the space between the ceiling and the roof, or floor, above.

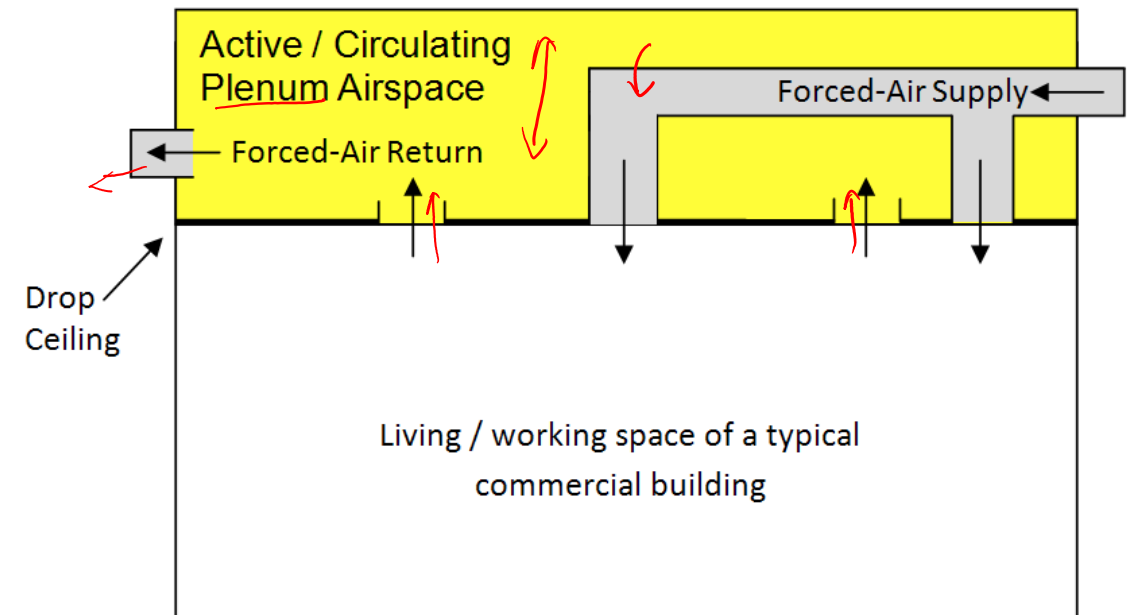
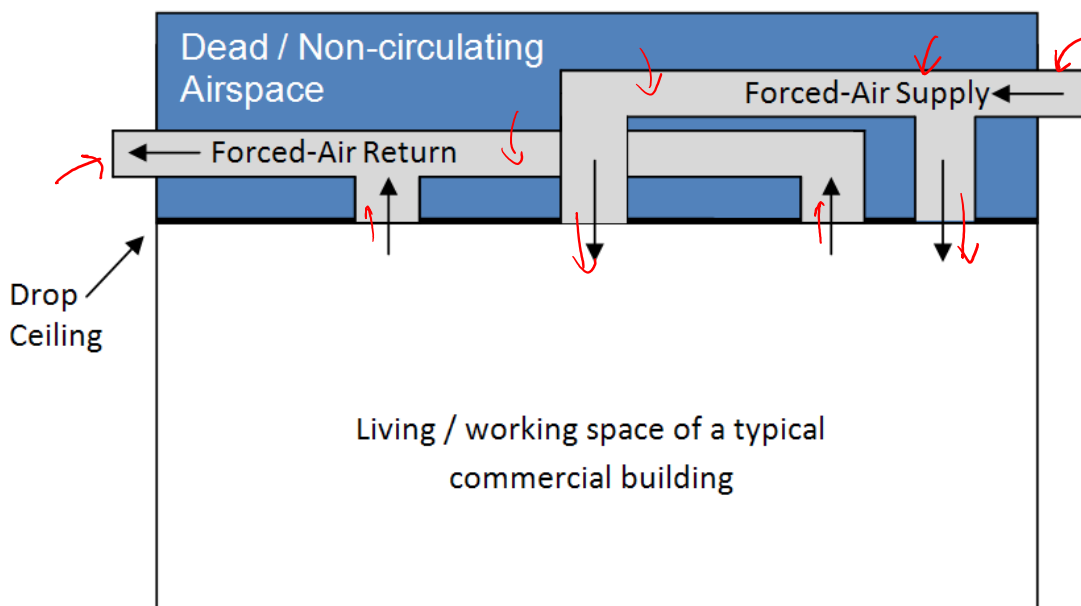

# Air-Water interface- Heat exchanger.

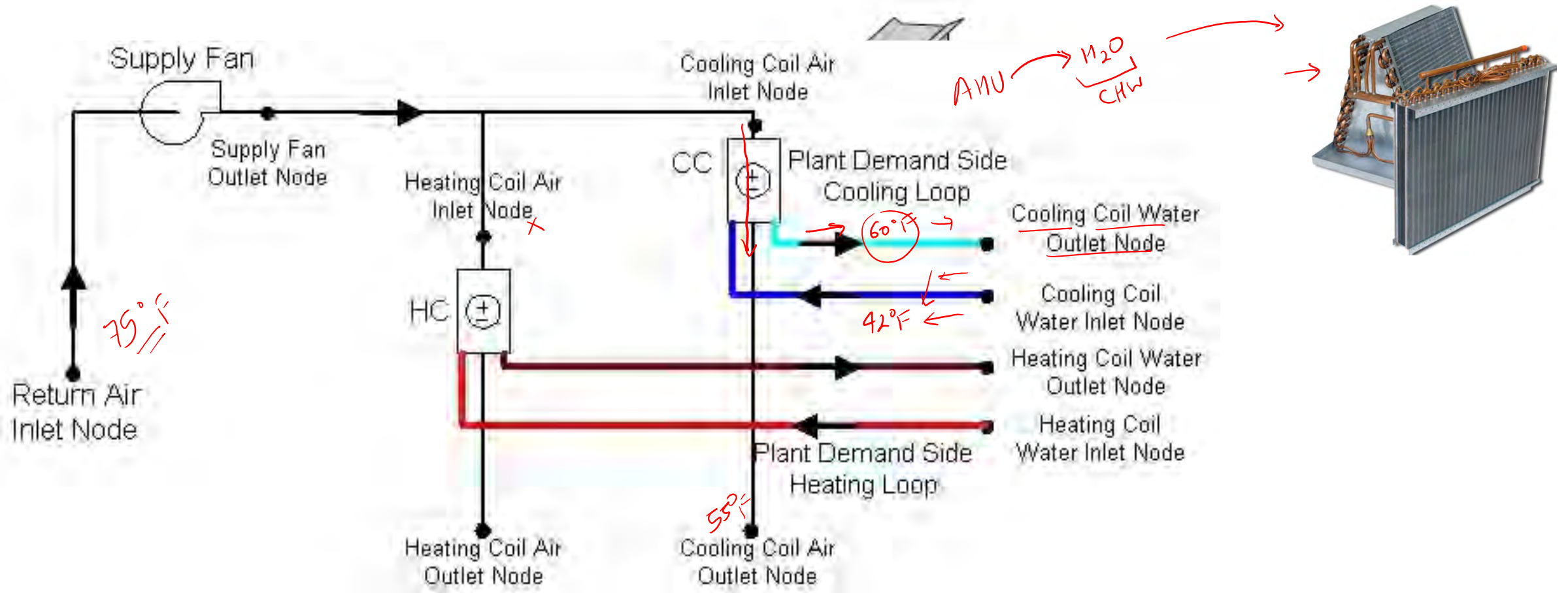

# Chilled water loop

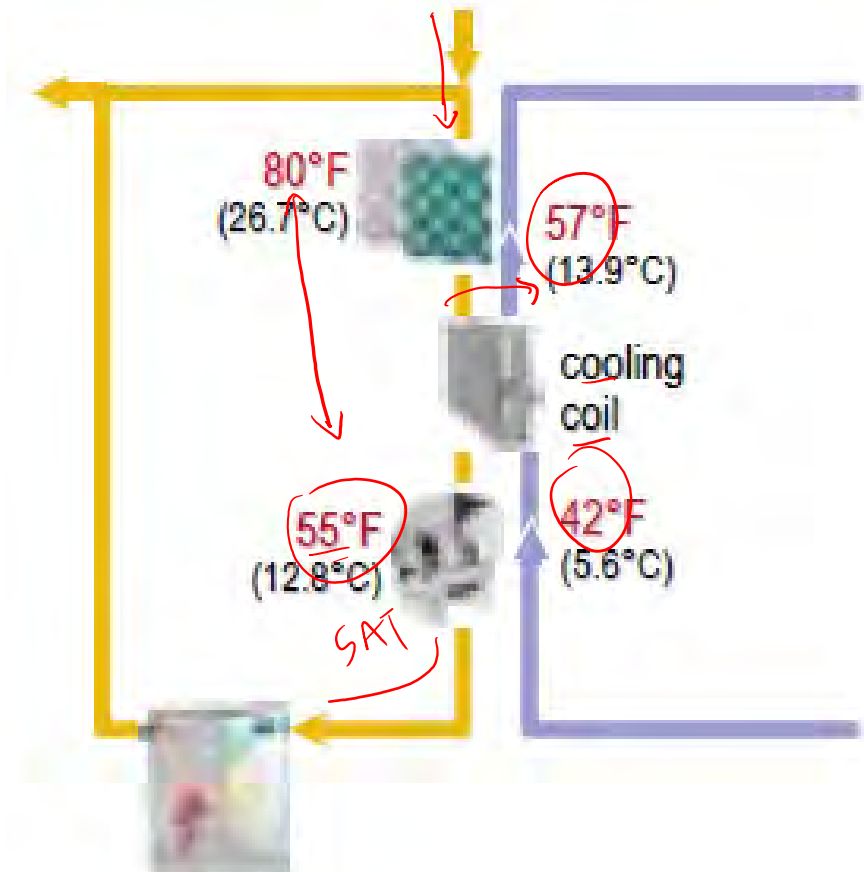
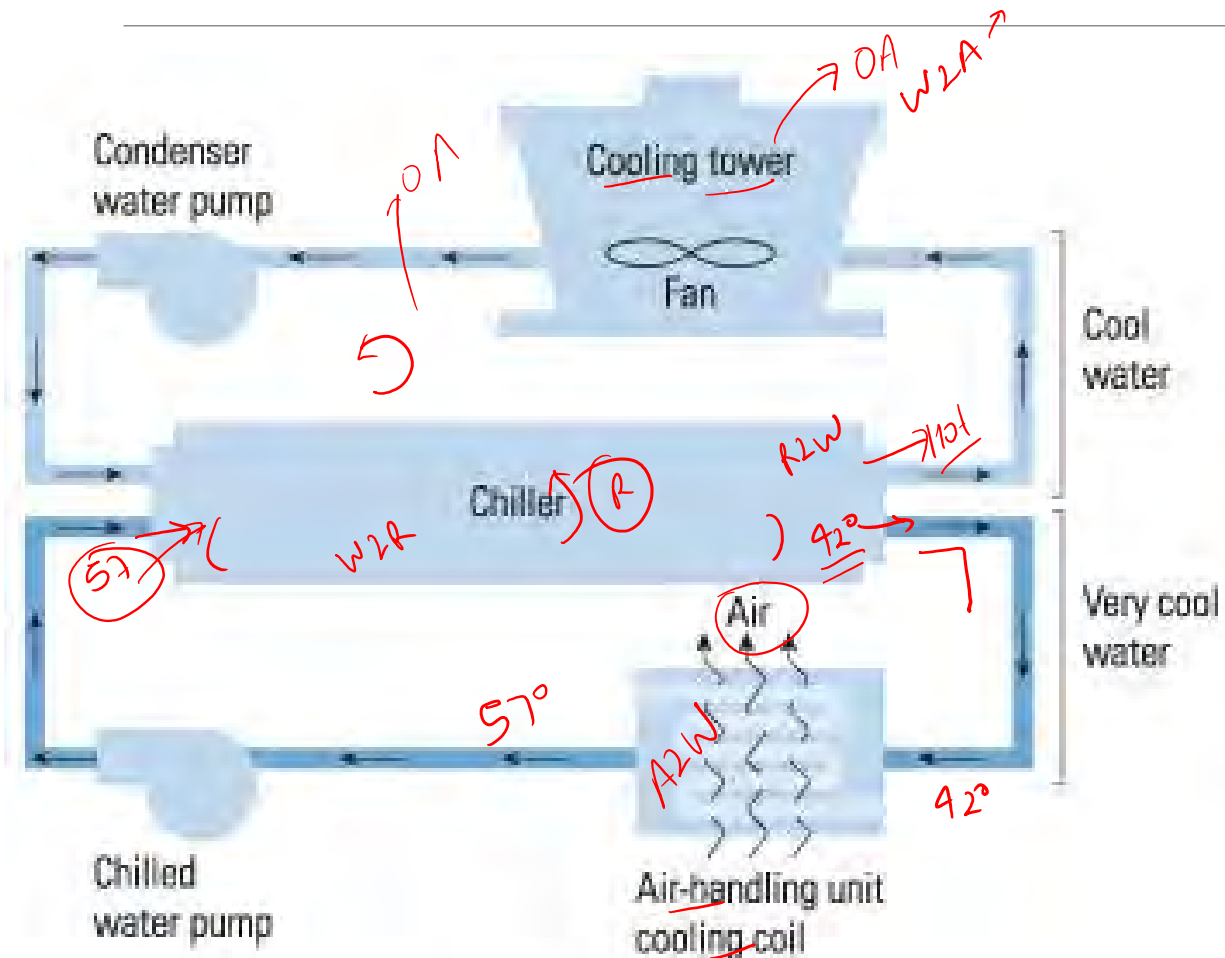

# Chiller plants

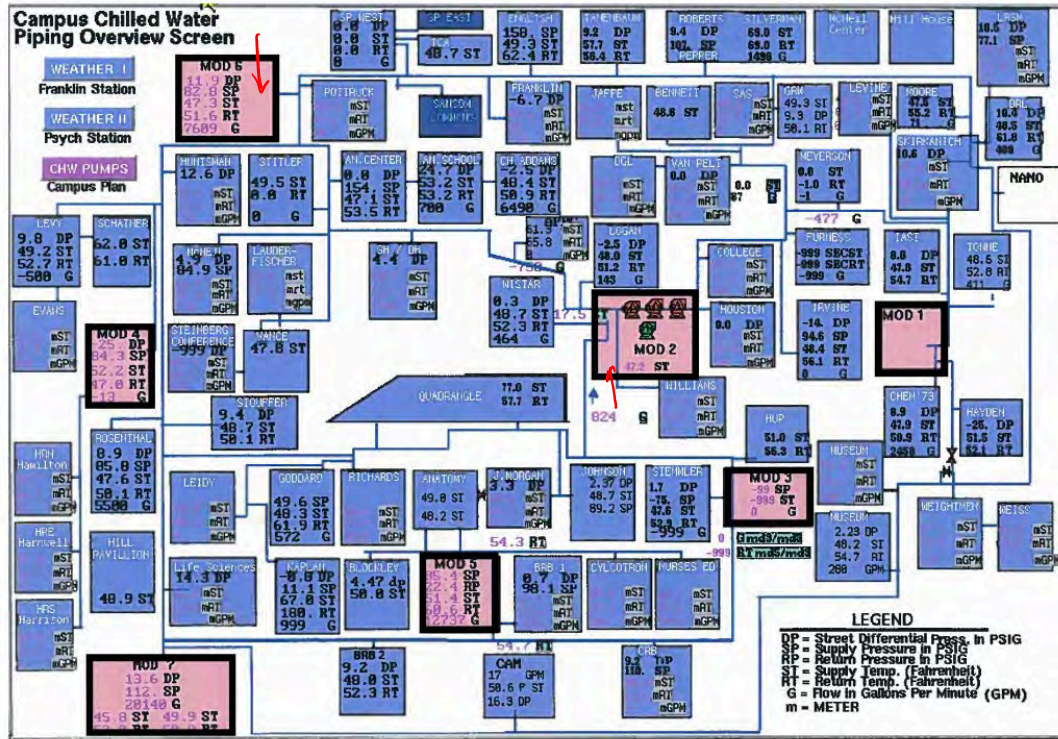

4 million gallons of water at 42 degree Fahrenheit

26 MW peak load

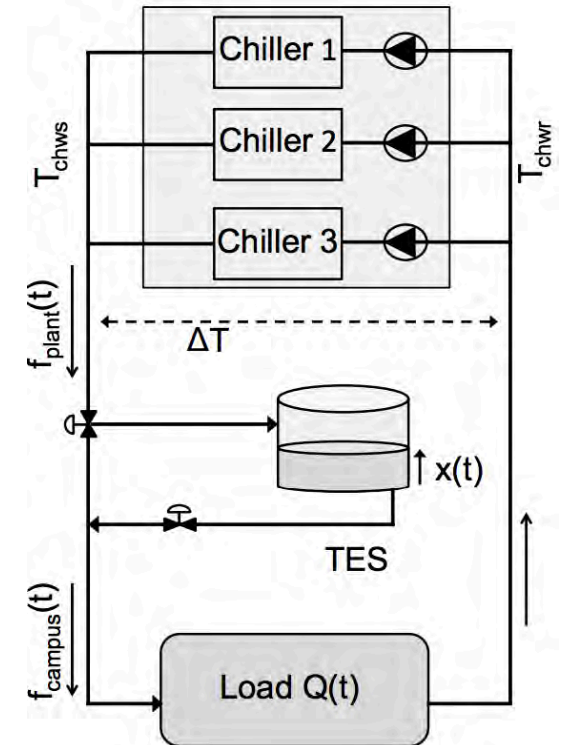



# Cooling towers

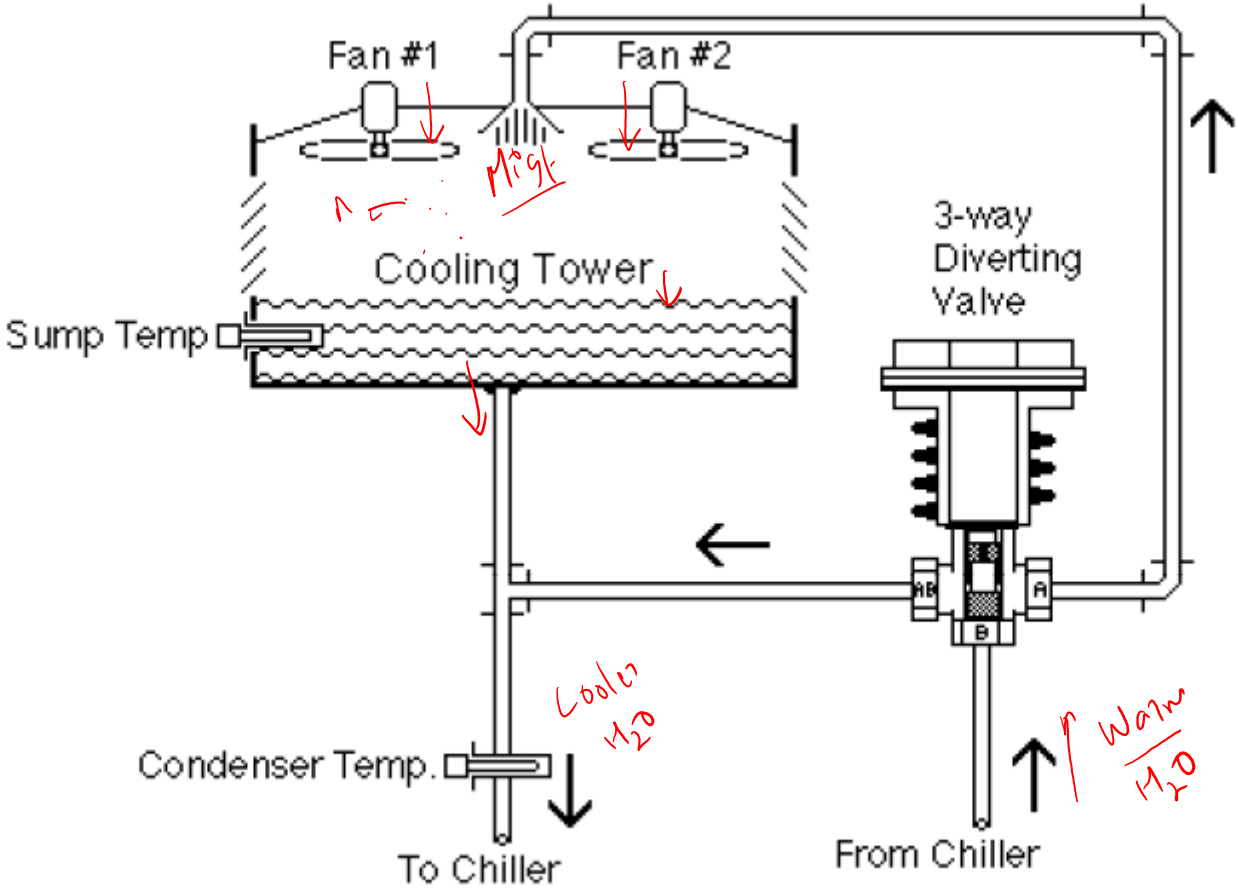

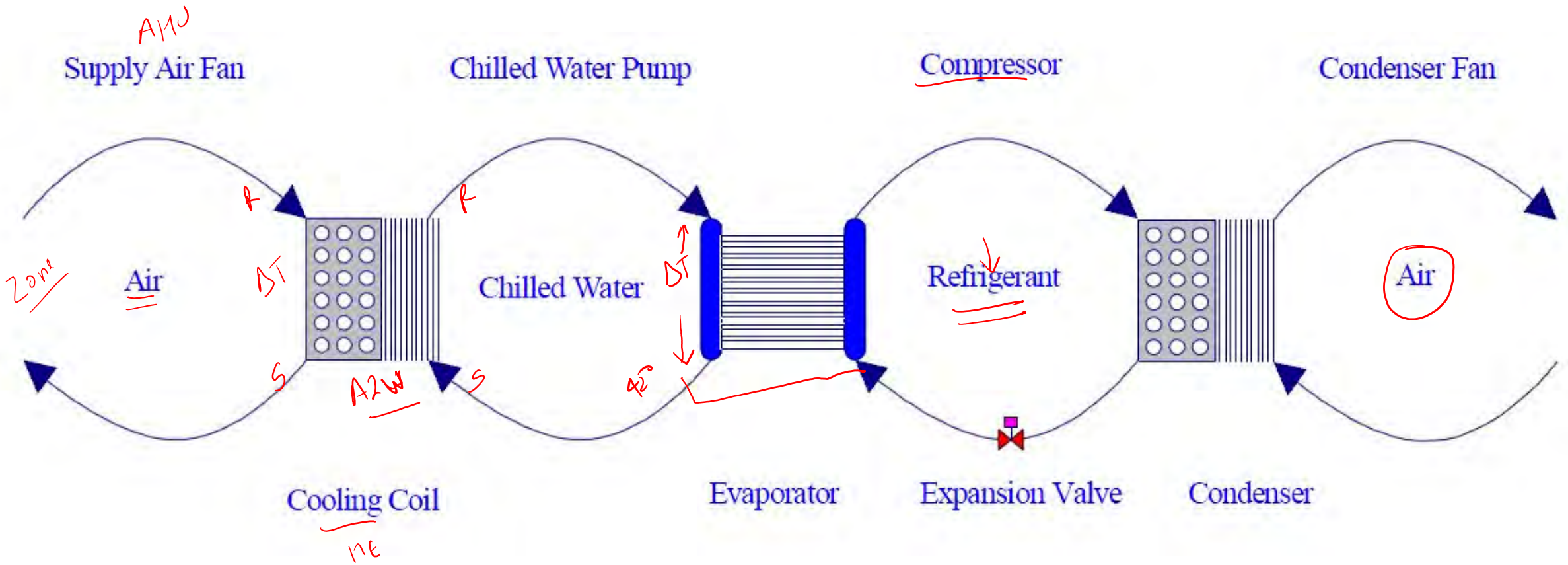

# Chiller plants

---

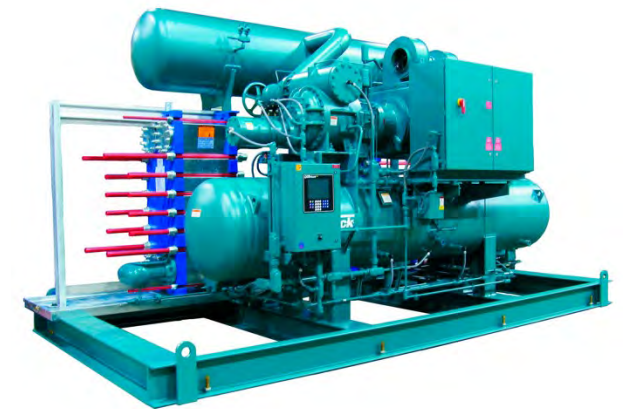
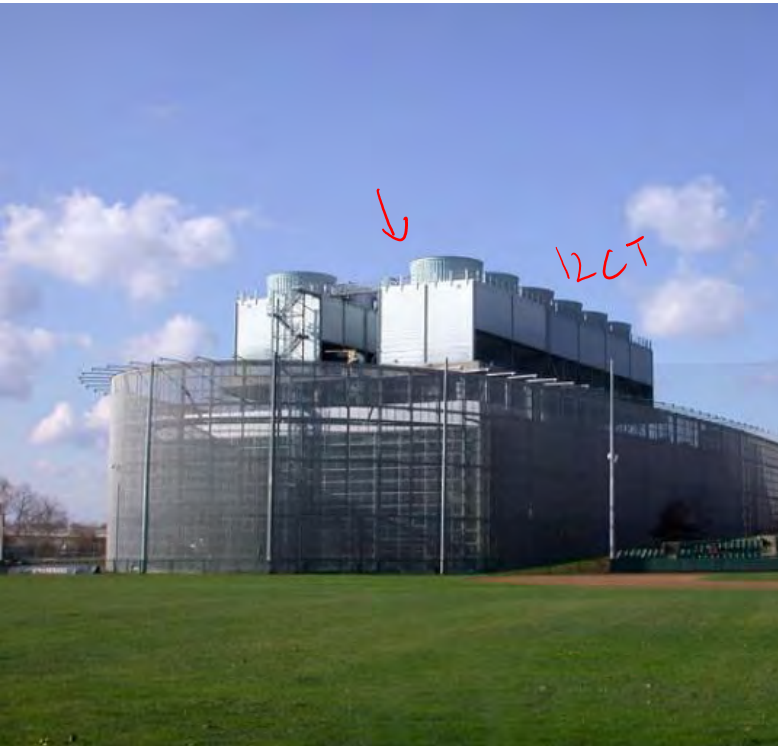

---

Just chilling as a  
grad student...





my biggest fans...

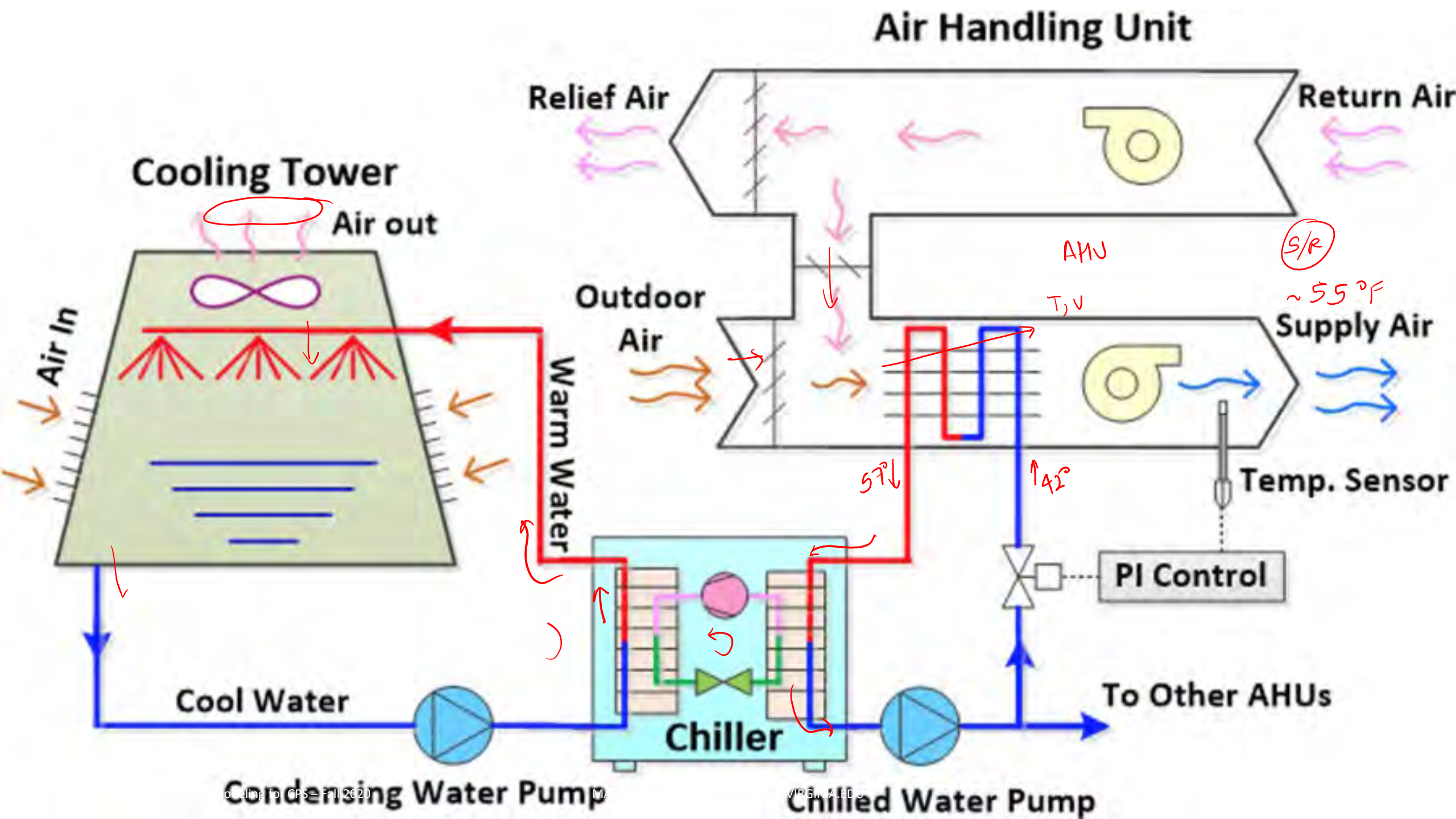

# Meeting zone loads

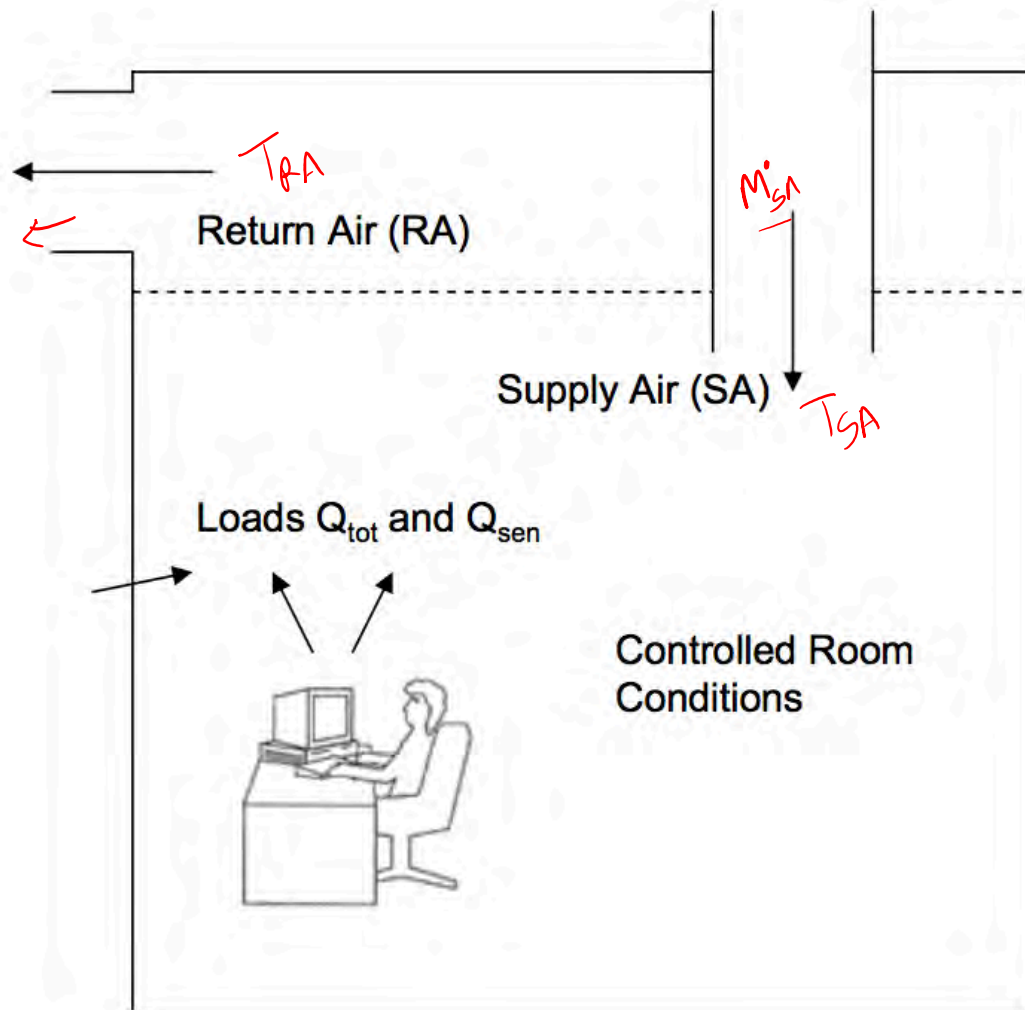

$$Q_{tot} = \dot{m}_{SA} (h_{RA} - h_{SA})$$

$$Q_{sen} = \dot{m}_{SA} c_p (T_{RA} - T_{SA})$$

Given controlled room air temperature, can control airflow or supply temperature to meet changing sensible loads

# VAV System:

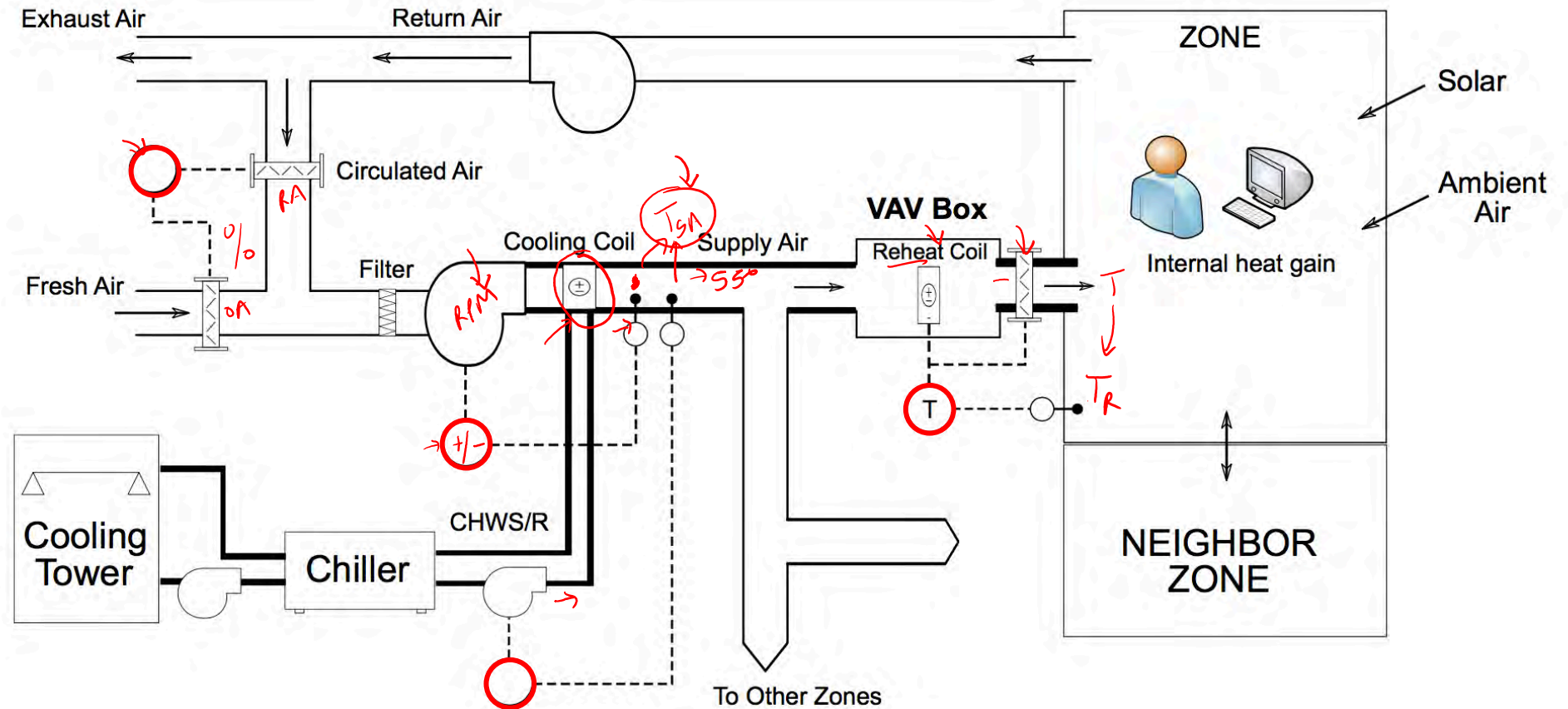

## Control loops

- ▶ Local control loops: thermostats, supply air controllers, etc.
- ▶ Supervisory control: set-points and modes for local control loops.



# Local control loops

## Zone temperature control loop (thermostat)

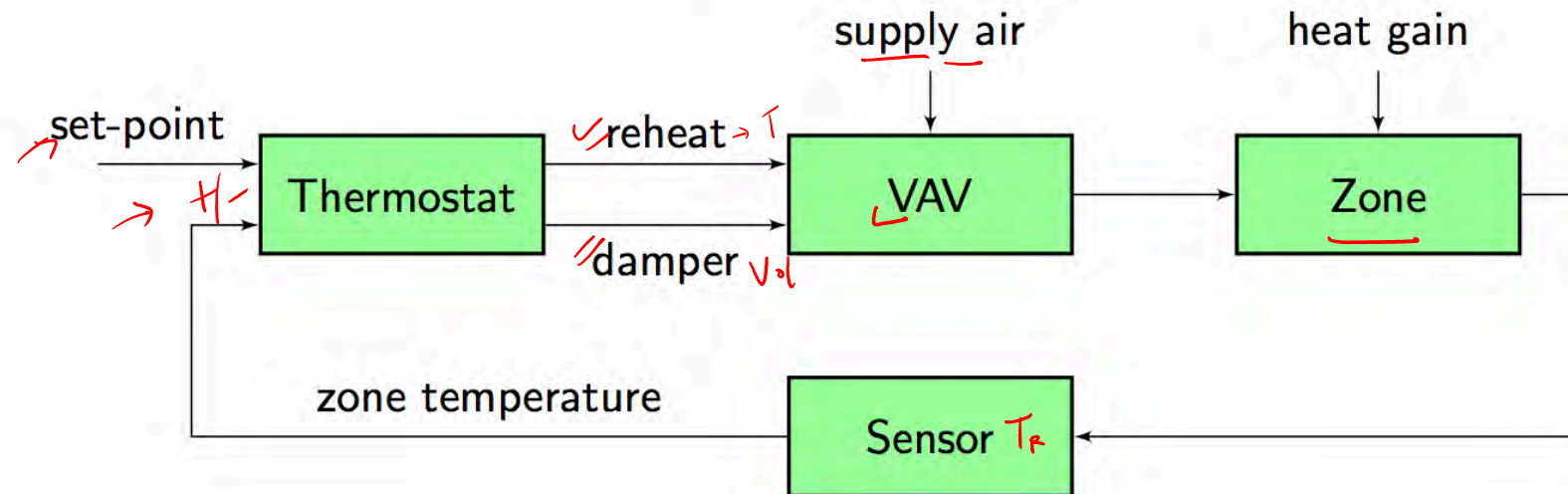

# Local control loops

## Supply Air Temperature (SAT) control loop

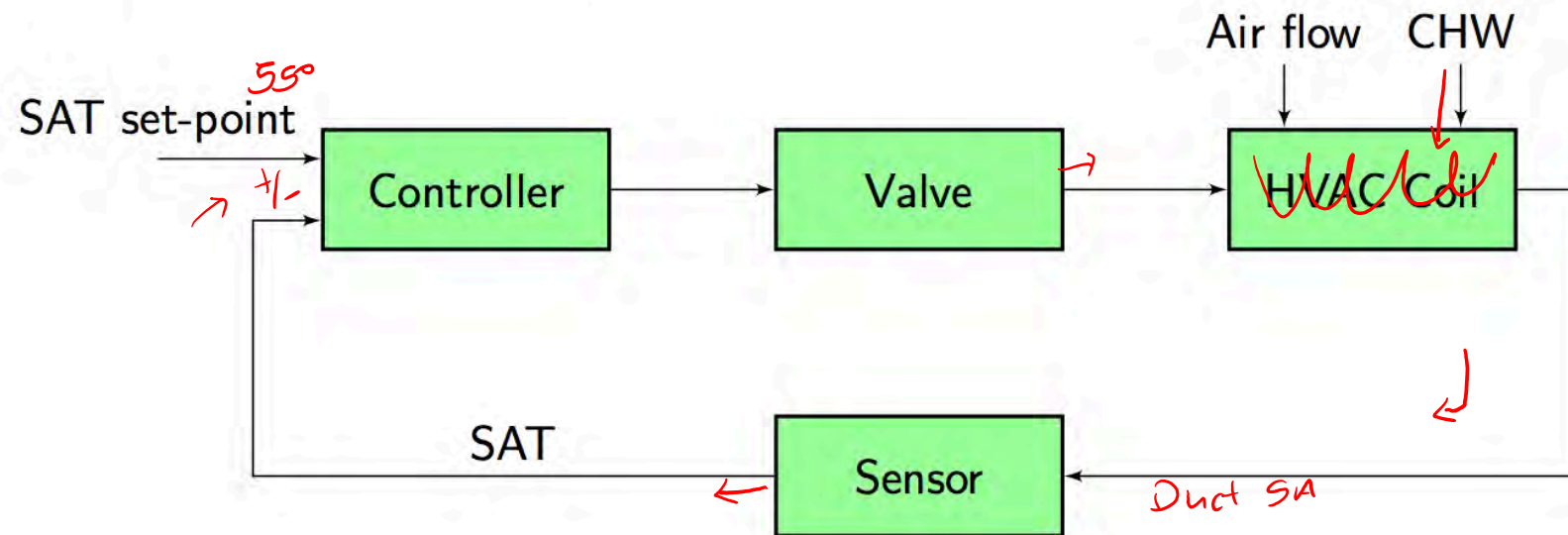

Simplest and common control is **on/off** control.

- ▶ Upper threshold  $t_u$ , lower threshold  $t_l$ , differential =  $t_u - t_l$ .
- ▶ Switch **off** when  $t \geq t_u$  and **on** when  $t \leq t_l$ .
- ▶ Time lag may cause larger operating differential.
- ▶ Suitable for thermostats (slow dynamics) but not for supply-air fan control.

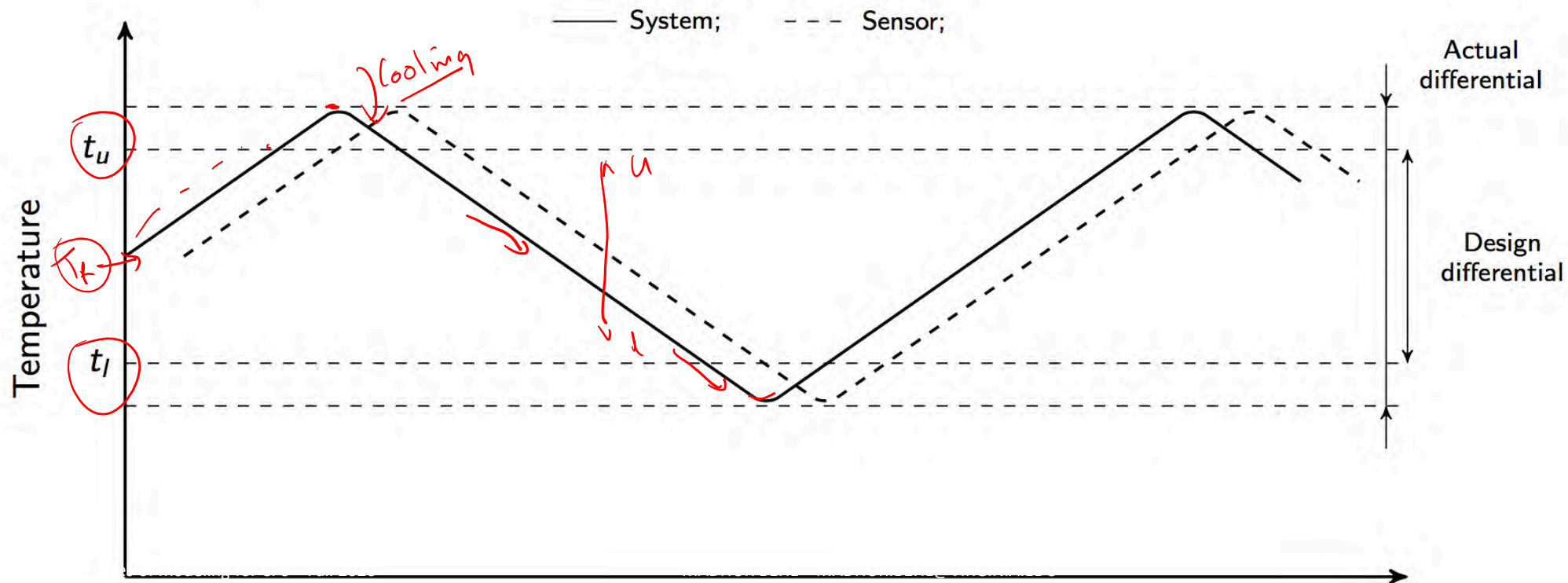

# Next lecture..

Creating a dynamical system model of a zone.

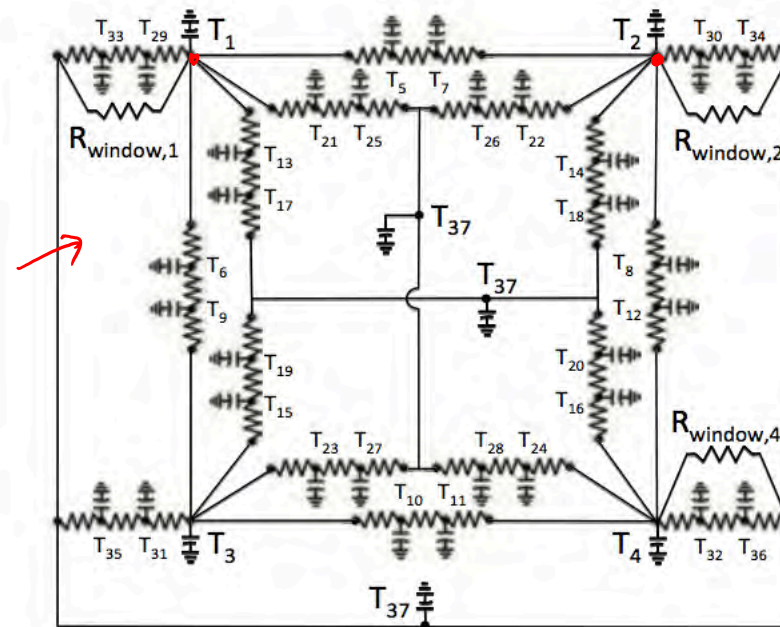

→ Thermal RC Model  
R  
-11-

$$\dot{x} = Ax + Bu$$

Source: [Deng et al., 2010]