

In today's lecture..

- Heat transfer basics
- Thermal gains
- Single zone 'RC' network model

Recall: HVAC zone control

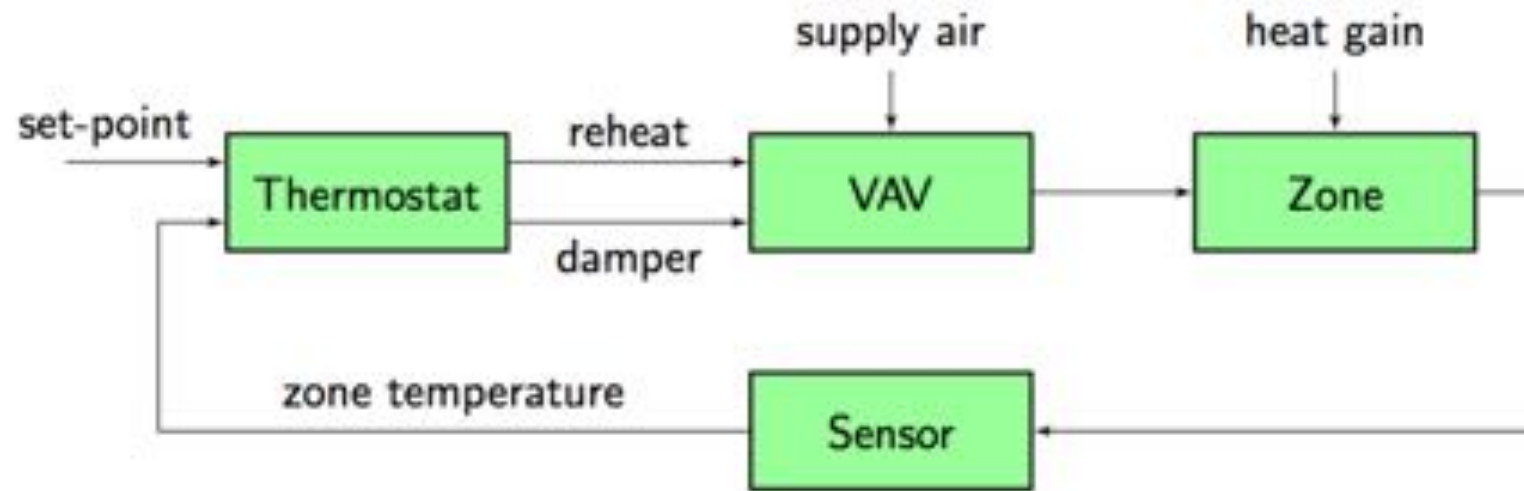

How to model the dynamics of the zone, for better control ?

Heat transfer concepts

- ▶ **Heat Q** : energy transferred across system boundary by temperature difference (J).
- ▶ **Heat flow (rate) \dot{Q}** : heat transfer rate (W).
- ▶ **Heat flux**: heat flow rate through a surface. **Heat flux density** is heat flux per unit area (W/m^2).

Heat transfer concepts

- ▶ **Heat capacity** C : heat needed to raise temperature of a body mass by 1°C (J/K). Also called *thermal mass*, *thermal capacitance*.
- ▶ **Specific heat (capacity)** C_p : heat needed to raise temperature of 1 kg of material by 1°C (J/kg K); $C = mC_p = \rho VC_p$.
- ▶ **Energy change** by temperature change $\Delta E = \rho VC_p \Delta T$.
- ▶ **Mass flow rate** \dot{m} (kg/s) and **volume flow rate** \dot{V} (m^3/s);
 $\dot{m} = \rho \dot{V}$.

Heat transfer 101

If a mass m_1 of a substance is heated from temperature T_1 to T_2 , the amount of heat H which it acquires is given by:

$$H = m_1 C_p (T_2 - T_1)$$

where C_p is the specific heat of the substance

Conservation of energy

Heat balance equation: $H - W = \Delta E$

Heat H Energy input to the system.

Work W Energy extracted from the system.

Internal heat E Energy stored in the system
(can only measure/calculate its change).

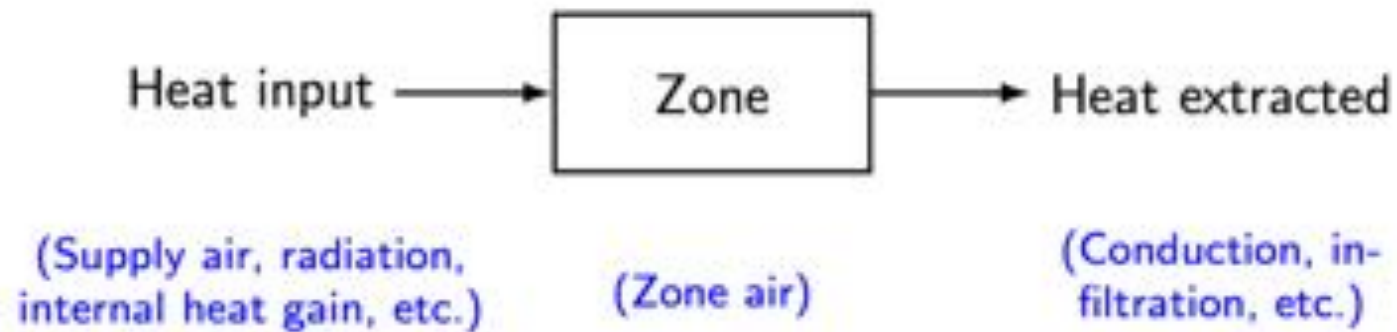

HVAC Zone heating

Supply air temperature T_s , return air temperature $T_r < T_s$, volume flow rate \dot{V} . Heat transfer to the zone is:

$$\dot{Q} = \dot{H} = \rho \dot{V} C_p (T_s - T_r) \quad (\text{W})$$

Heat flow

mass flow rate..

Zone Cooling

Similarly, with $T_s < T_r$, heat extracted from the zone is:

$$\dot{Q} = \dot{W} = \rho \dot{V} C_p (T_r - T_s) \quad (\text{W})$$

Components of Building Heat Loss and Gain

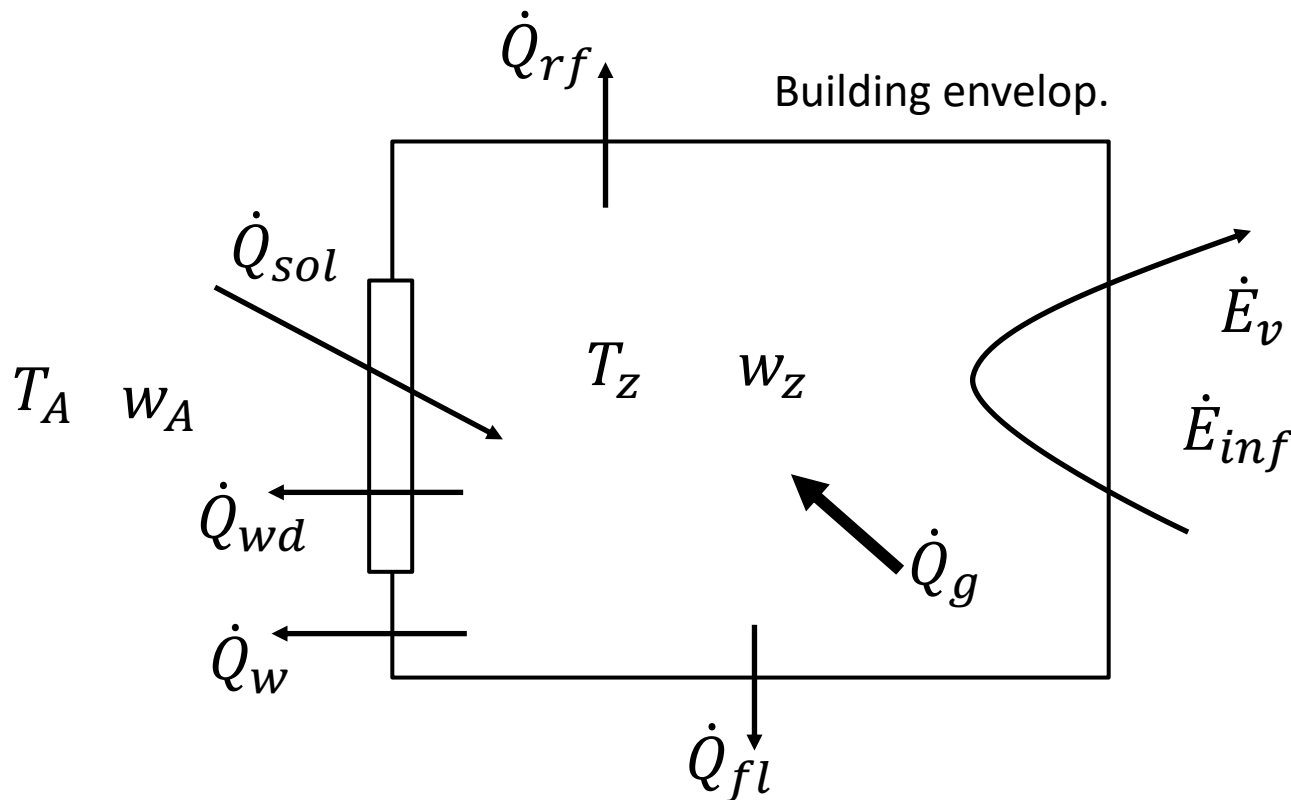

- Gains
 - Heat flows in...
- Losses
 - Heat flows out...
- Sensible gain/cooling:
 - Change the temperature of the interior air.
- Latent gain/cooling:
 - Change the humidity level of the interior air.

Components of Building Heat Loss and Gain

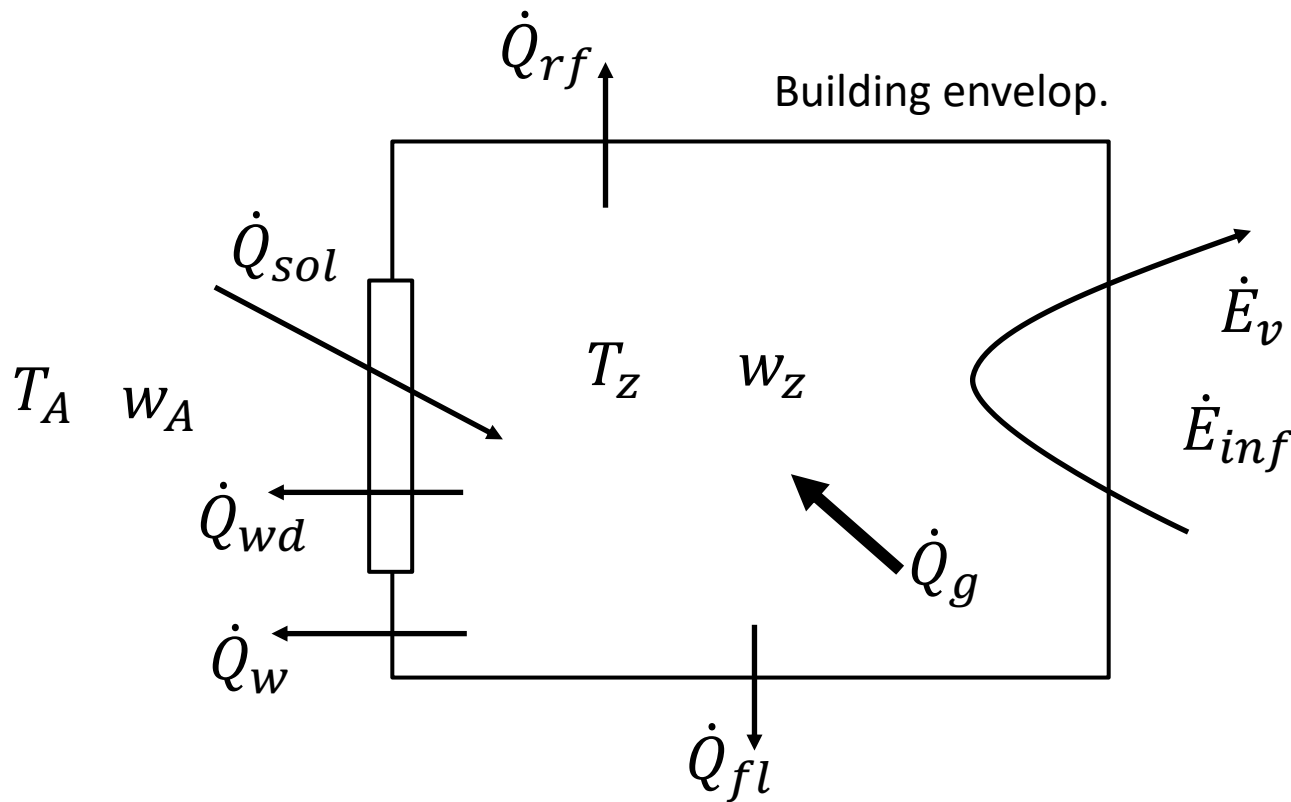

- Heat flows through:
 - Walls
 - Windows
 - Doors
 - Roof
 - Floor
 - Internal heat gain
 - Lights
 - Occupants
 - Equipment

Mechanisms of heat transfer

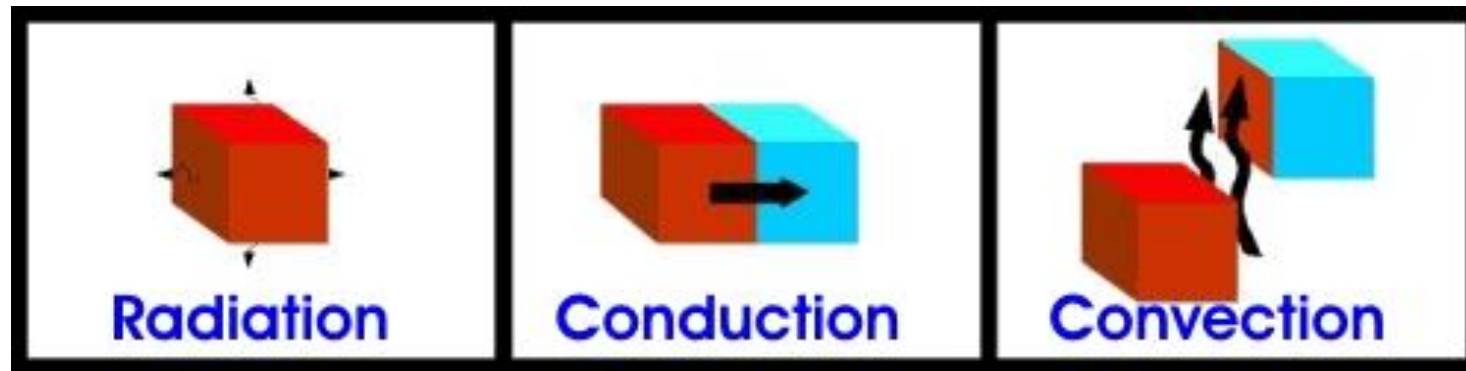

Conduction – A touching story of heat transfer

Conduction is the process of heat transfer through a substance such as a wall, from higher to lower temperature.

Fourier's equation (3-dimensional PDE with time):

$$\rho C_p \frac{dT}{dt} = k \left[\frac{\partial^2 T}{\partial x^2} + \frac{\partial^2 T}{\partial y^2} + \frac{\partial^2 T}{\partial z^2} \right]$$

where k : thermal conductivity (W/mK).

Heat Transfer: Conduction

Simplified equation (timeless, one-dimensional):

$$\dot{Q} = kA \frac{\Delta T}{\Delta x} = kA \frac{T_h - T_l}{l}$$

where A : cross-sectional area (m^2), T_h : high temperature, T_l : low temperature, l : thickness/length of material.

Heat Transfer: Conduction

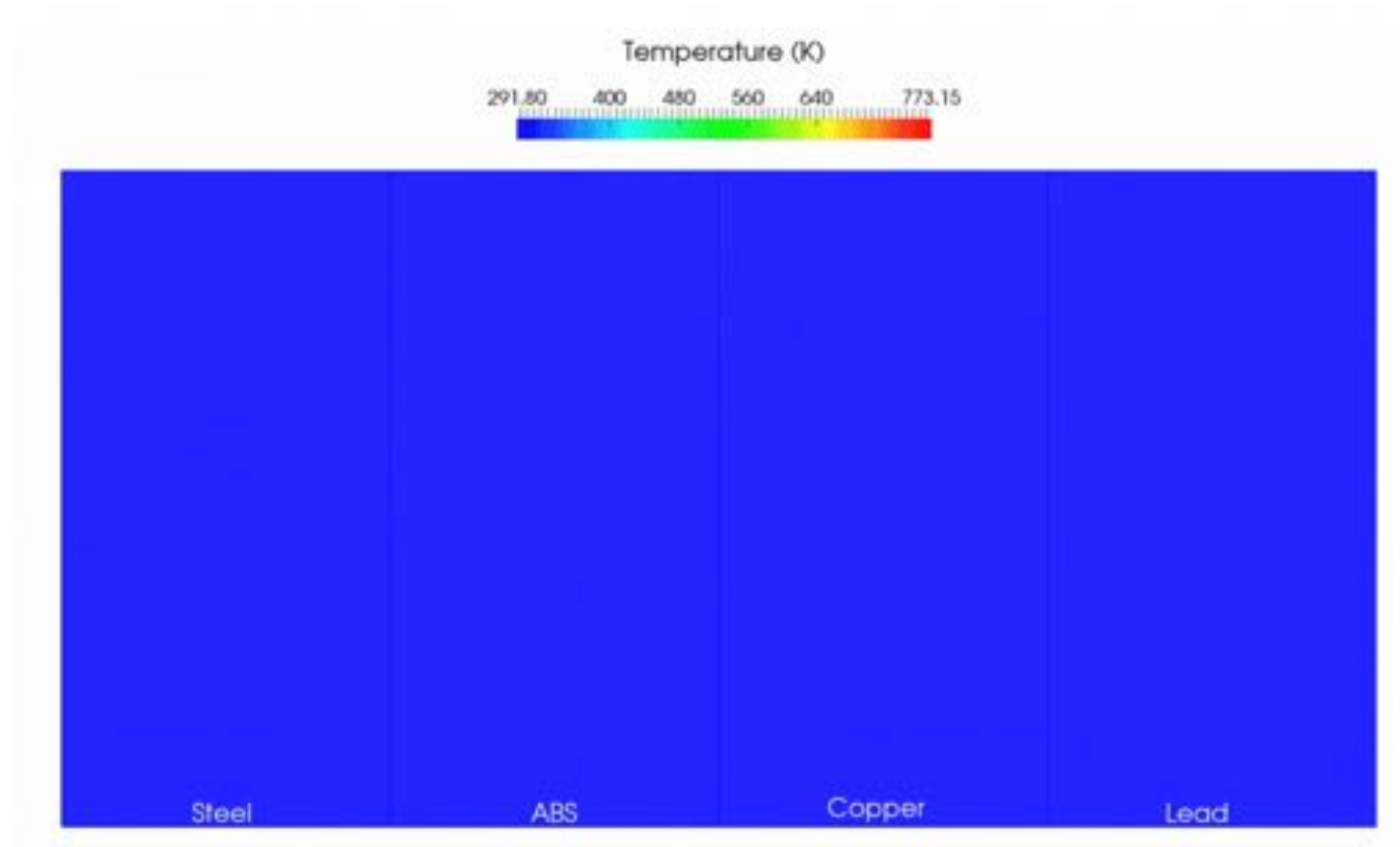

Conduction through a wall

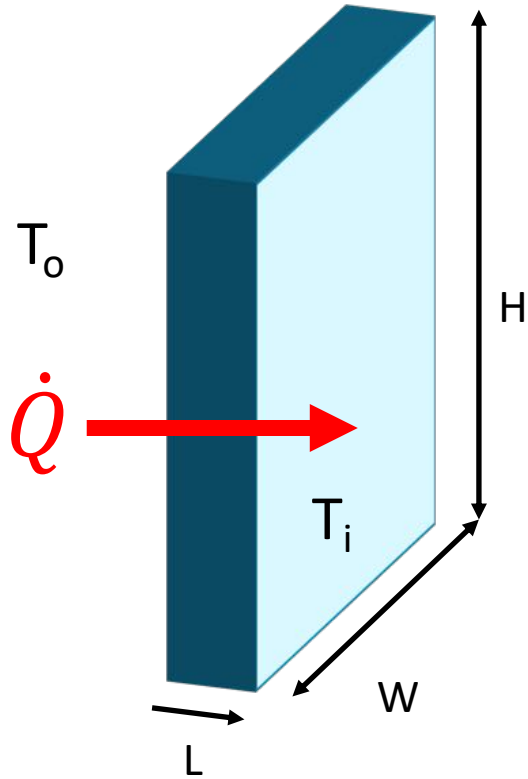

$$\dot{Q} = kA \frac{T_o - T_i}{L}$$

$$\dot{Q} = \frac{T_o - T_i}{R_w}$$

$$R_w = \frac{L}{kA}$$

Property of the geometry

Property of the material

Recall: Generalized resistance

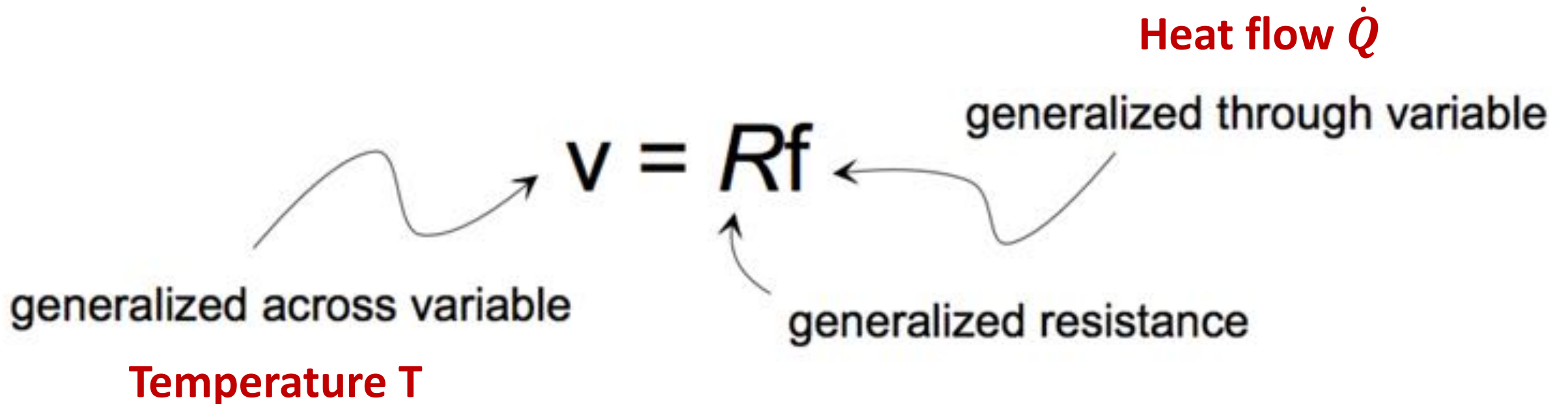

Heat Transfer: Conduction

Define $R_{th} = \frac{1}{kA}$ (thermal resistance) then

Through Variable \dot{Q} $R_{th} = T_h - T_l$ Across Variable

Equivalent to an electric circuit: $T =$ potential, $\Delta T =$ voltage, $\dot{Q} =$ current, $R_{th} =$ resistance.

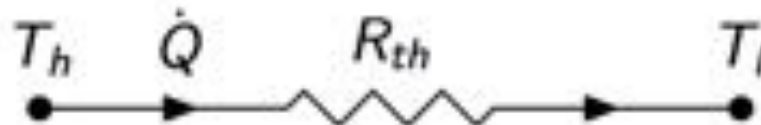

Composite wall

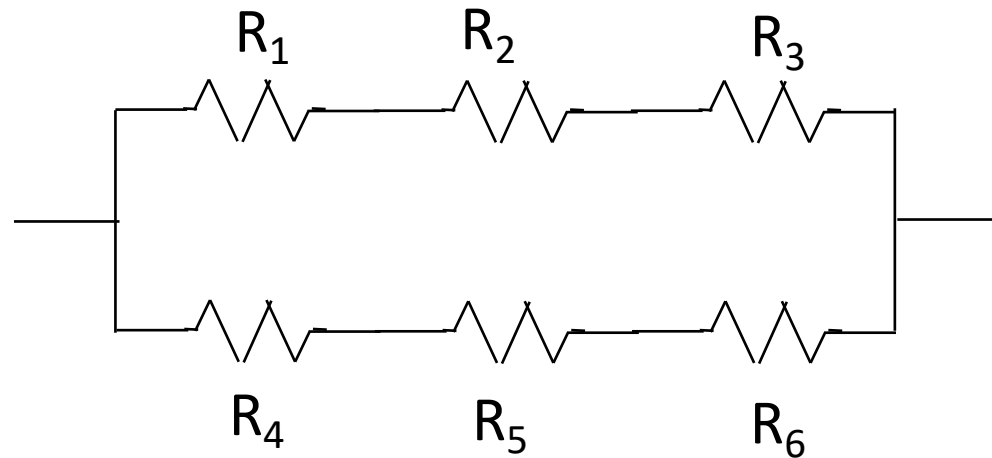
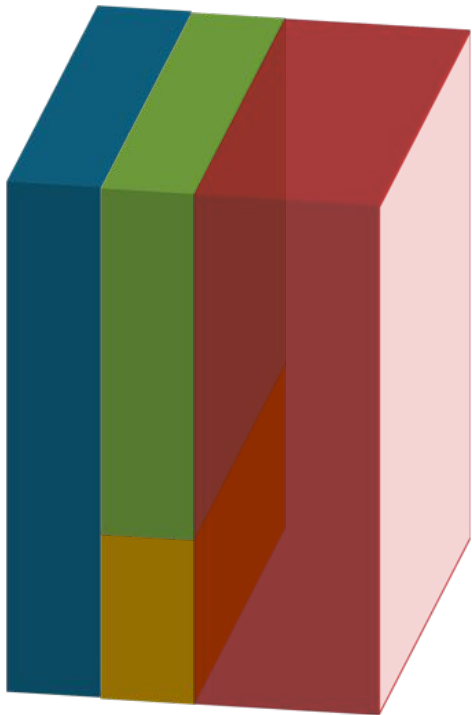

Equivalent to

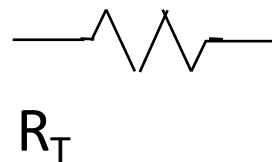

$$R_T = \frac{1}{\left[\left(\frac{1}{R_1 + R_2 + R_3} \right) + \left(\frac{1}{R_4 + R_5 + R_6} \right) \right]}$$



Heat Transfer: Convection

Convection is the heat transfer between a surface and fluid/gas by the movement of the fluid/gas.

- ▶ Natural convection: heat transfer from a radiator to room air.
- ▶ Forced convection: from a heat exchanger to fluid being pumped through.

Heat Transfer: Convection

Second law (of thermodynamics)

Newton's law of cooling: $\dot{Q} = hA\Delta T$

where h : heat transfer coefficient ($\text{W}/\text{m}^2\text{K}$); A : surface area (m^2),
 ΔT : temperature difference between surface and fluid.

Define $R_{cv} = \frac{1}{hA}$ and write $\dot{Q}R_{cv} = \Delta T$.

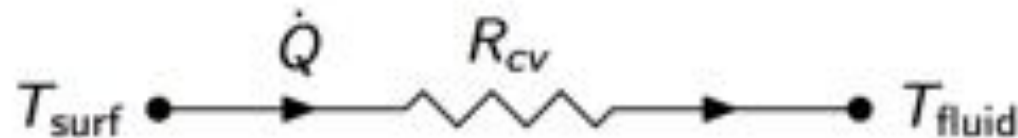

Property of the geometry

Property of the material

Heat Transfer: Radiation

Radiation is the heat transfer through space by electromagnetic waves.
Example: radiation between a radiator and a wall that faces it.

Fourth-order equation given by the Stefan-Boltzman law (cf. heat transfer textbooks).

Approximate linearized equation:

$$\dot{Q} = \epsilon h_r A (T_1 - T_2)$$

where ϵ : emissivity of the surface (0.9 for most building materials); h_r : radiation heat transfer coefficient ($\text{W}/\text{m}^2 \text{K}^2$).

Heat Transfer: Radiation

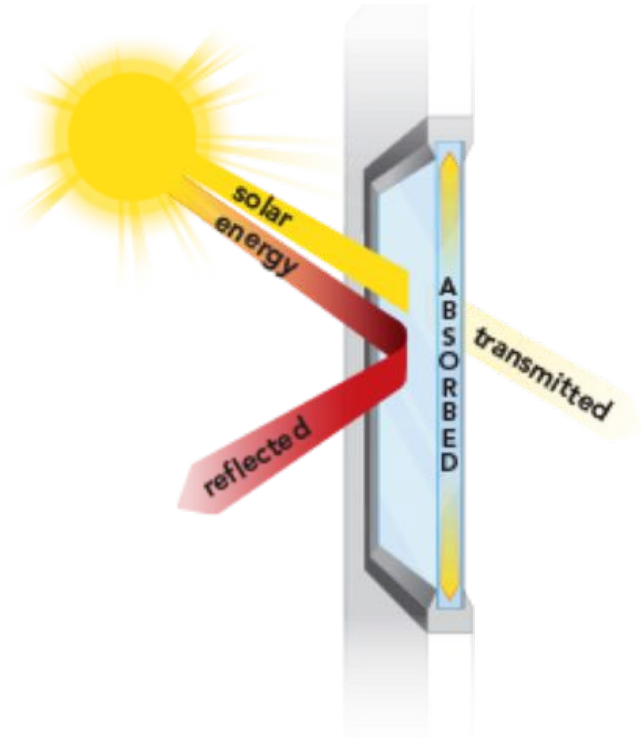

Direct

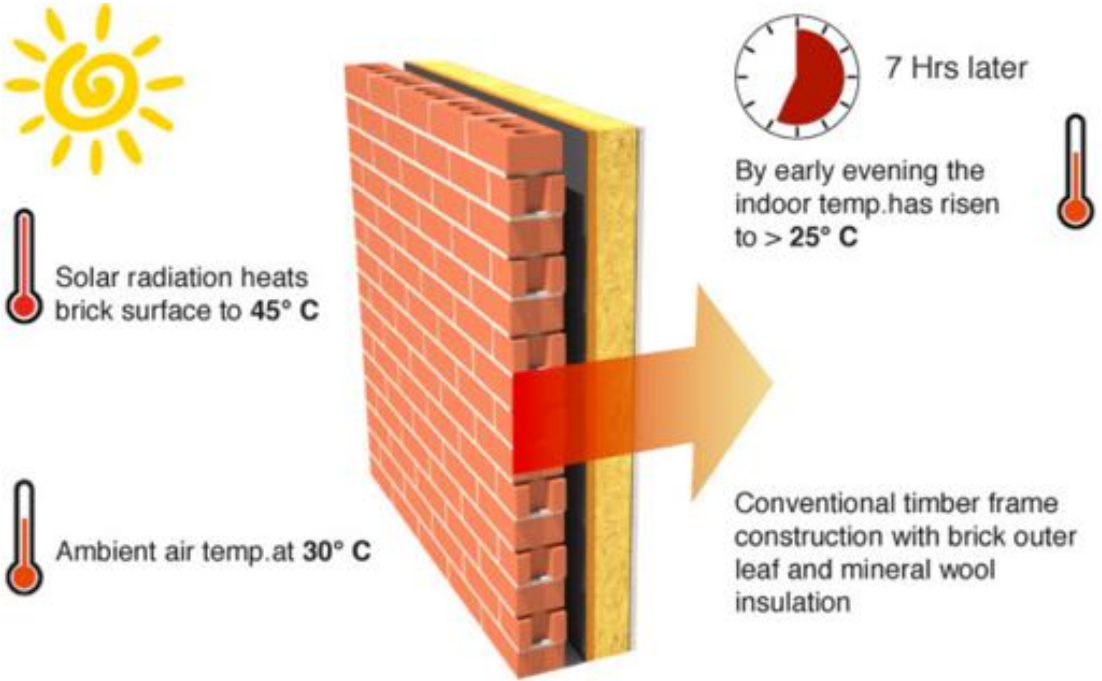

Indirect

Heat Transfer: Radiation

Define $R_r = \frac{1}{\epsilon h_r A}$ and write $\dot{Q} R_r = \Delta T$.

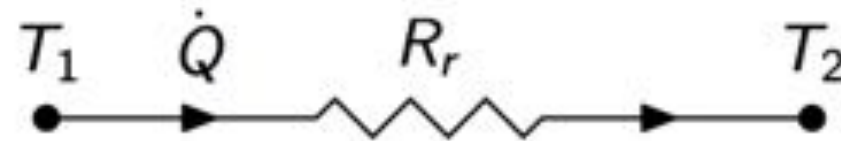

Recall: Generalized Capacitance

Temperature T

generalized through variable

Heat flow \dot{Q}

$$f = C \frac{dv}{dt}$$

generalized across variable

generalized capacitance

Thermal Mass

$$C_{\text{thermal mass of material volume}} \frac{dT_{\text{material}}}{dt} = \dot{Q}_{\text{net loss/gain}}$$

To model a single zone:

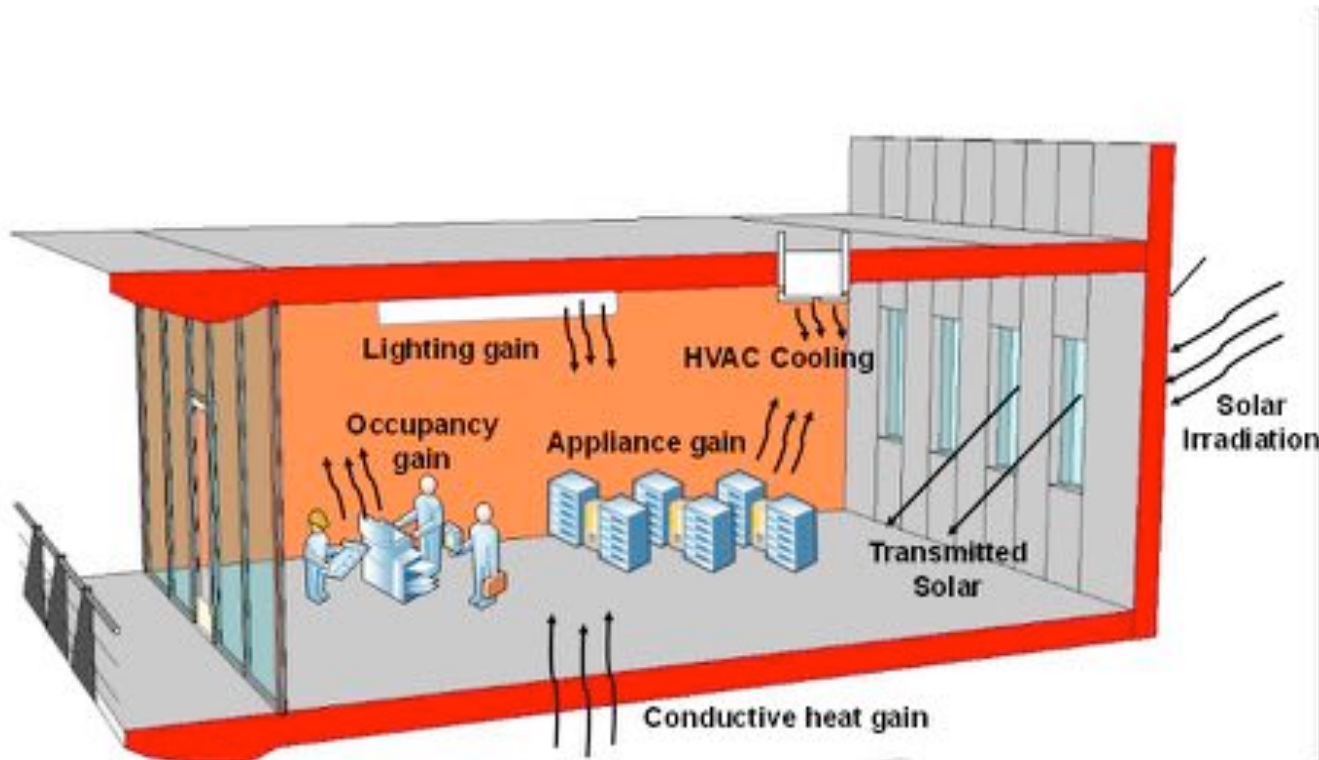

1. To predict...

- Zone temperature.
- Zone humidity.
- Electricity consumption/demand.
- Energy consumption/demand.
 - Cooling load
 - Heating load

To model a single zone:

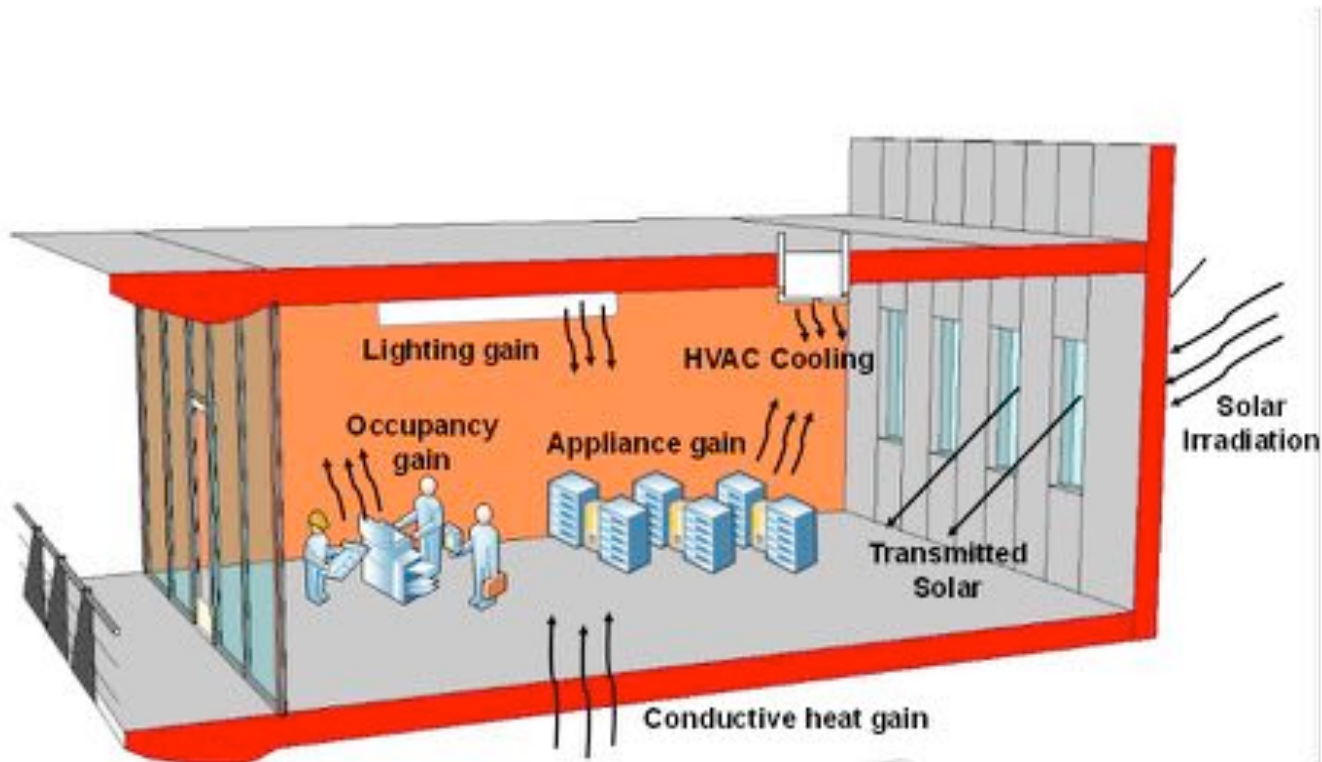

We could model

- HVAC equipment.
- Building envelop.

To model a single zone:

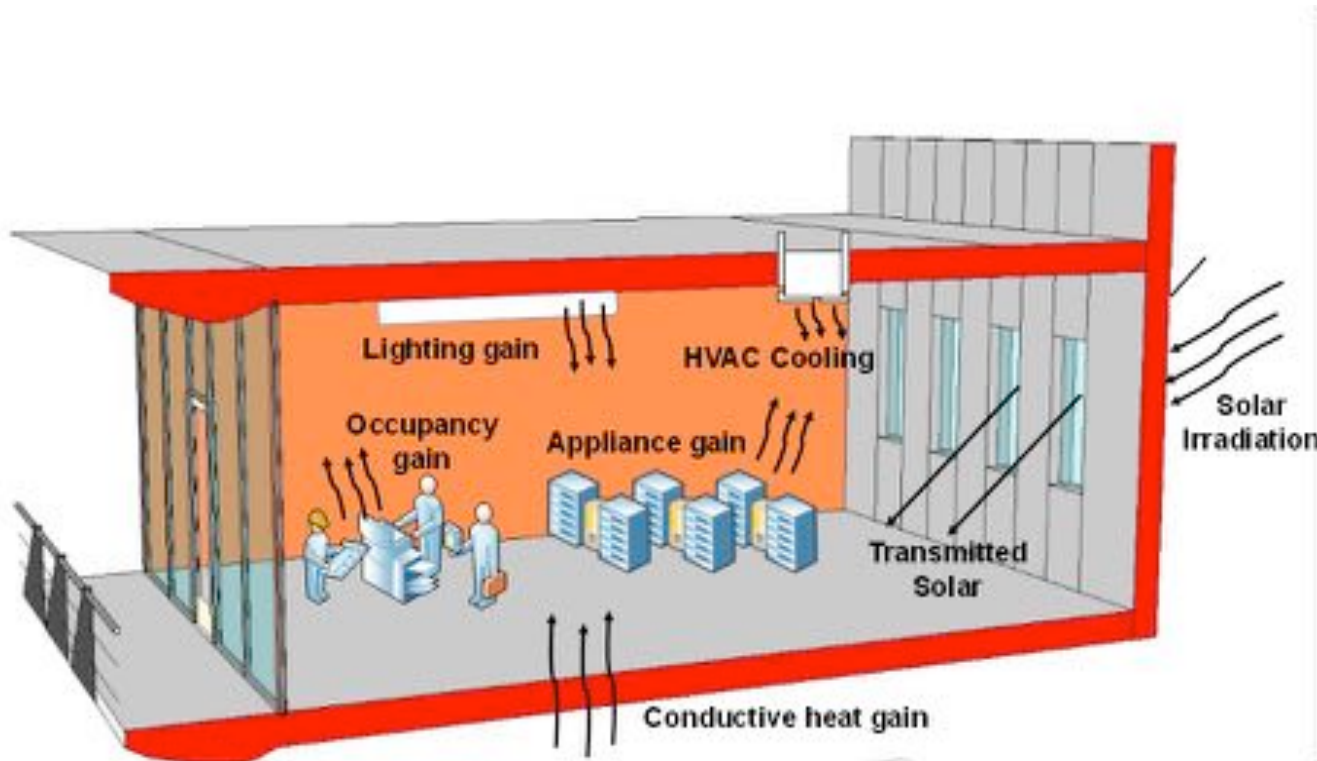

1. Construction:

1. Material properties

2. Geometry:

1. Surface Areas,
2. Surface thickness
3. Volume

3. Operation:

1. Internal heat gains
2. HVAC cooling/heating
3. Outside air
4. Solar heat gain

Single zone: Surfaces

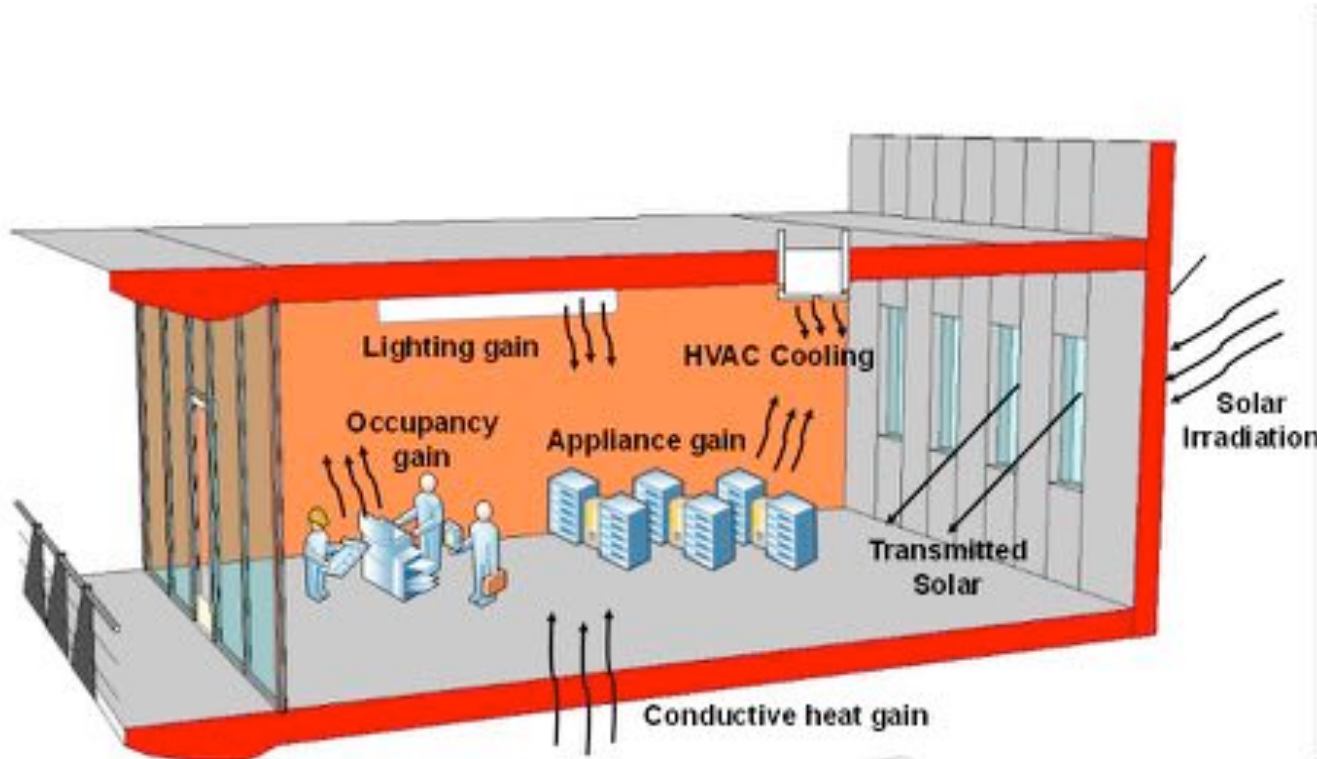

1. External Walls:

1. Outside surface of external wall – Ambient temperature.
2. Inside surface of external wall – Zone temp.

2. Ceiling:

1. Out surf : Ambient temp, or floor of the zone above.
2. Special case: Plenum
3. In surface: zone temp

3. Floor:

1. Out surf: Ground temp, or zone below..
2. In surface: zone temp

4. Internal Walls:

1. With adjacent zones.

5. Windows/Doors

Single zone: Heat Gains

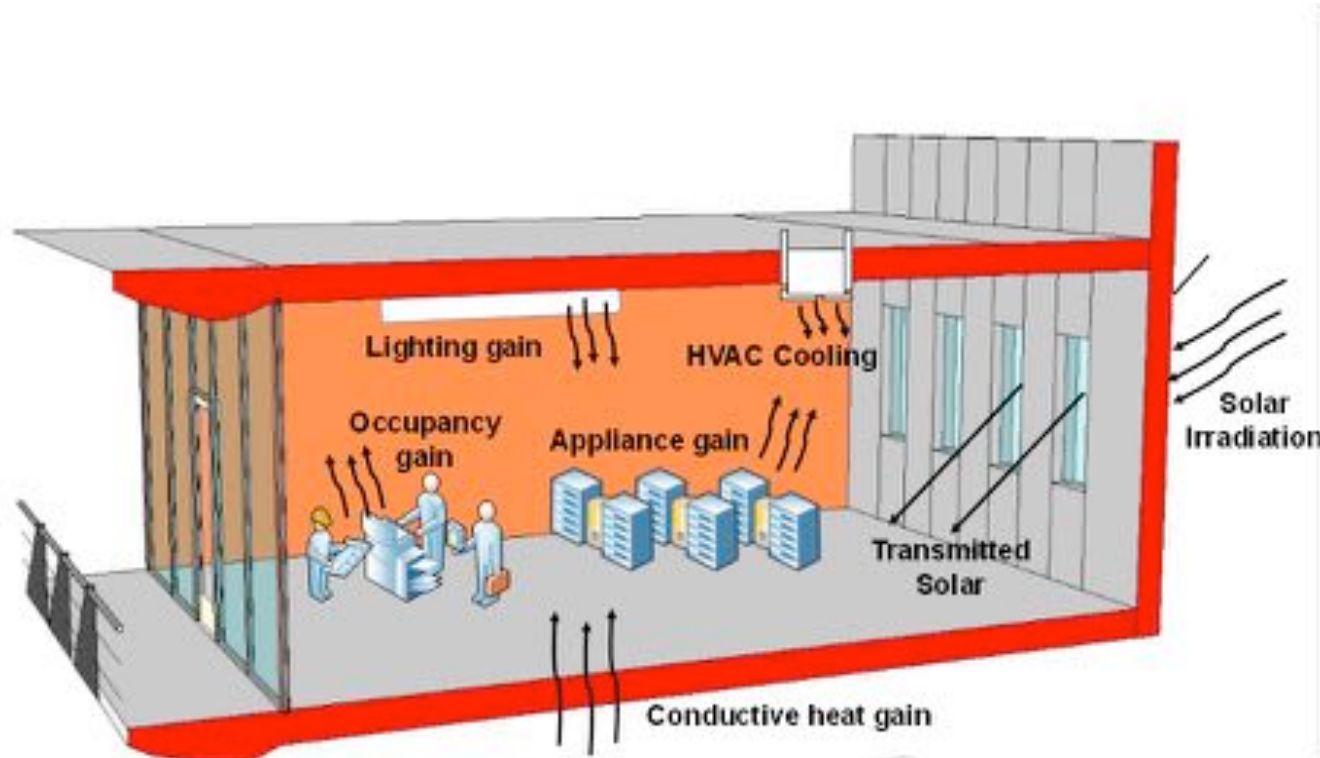

1. Solar Irradiance Q_{sol} :
 1. External wall
 2. Ceiling
2. Solar radiation transmitted through windows $Q_{sol,t}$:
 1. Absorbed by zone air, and internal surfaces.
3. Radiative internal heat gain Q_{rad} :
 1. Distributed evenly on all internal surfaces.
4. Convective heat gain Q_{conv} :
 1. With adjacent zones.
5. HVAC heat gain Q_{HVAC} or Q_{sens}
6. Boundary temperatures:
 1. Outside air temp.
 2. Other zones

Internal heat gains

Occupants

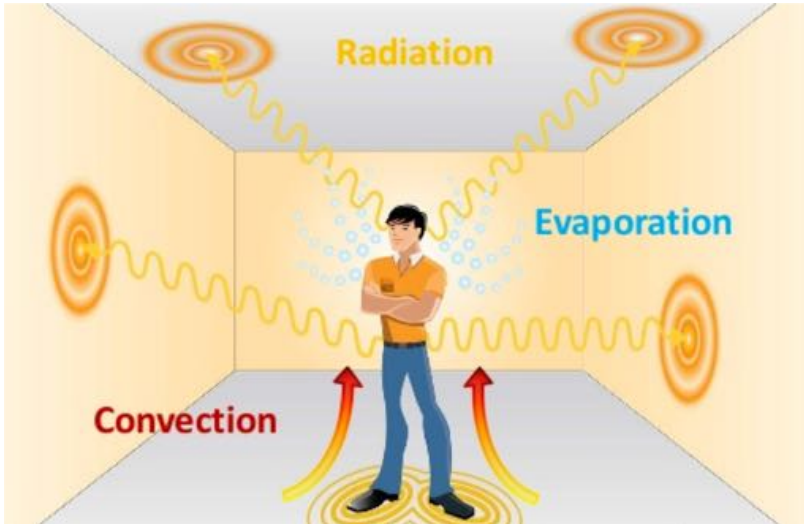

Lighting



Appliances/Equipment



Radiative

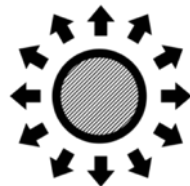

Convective

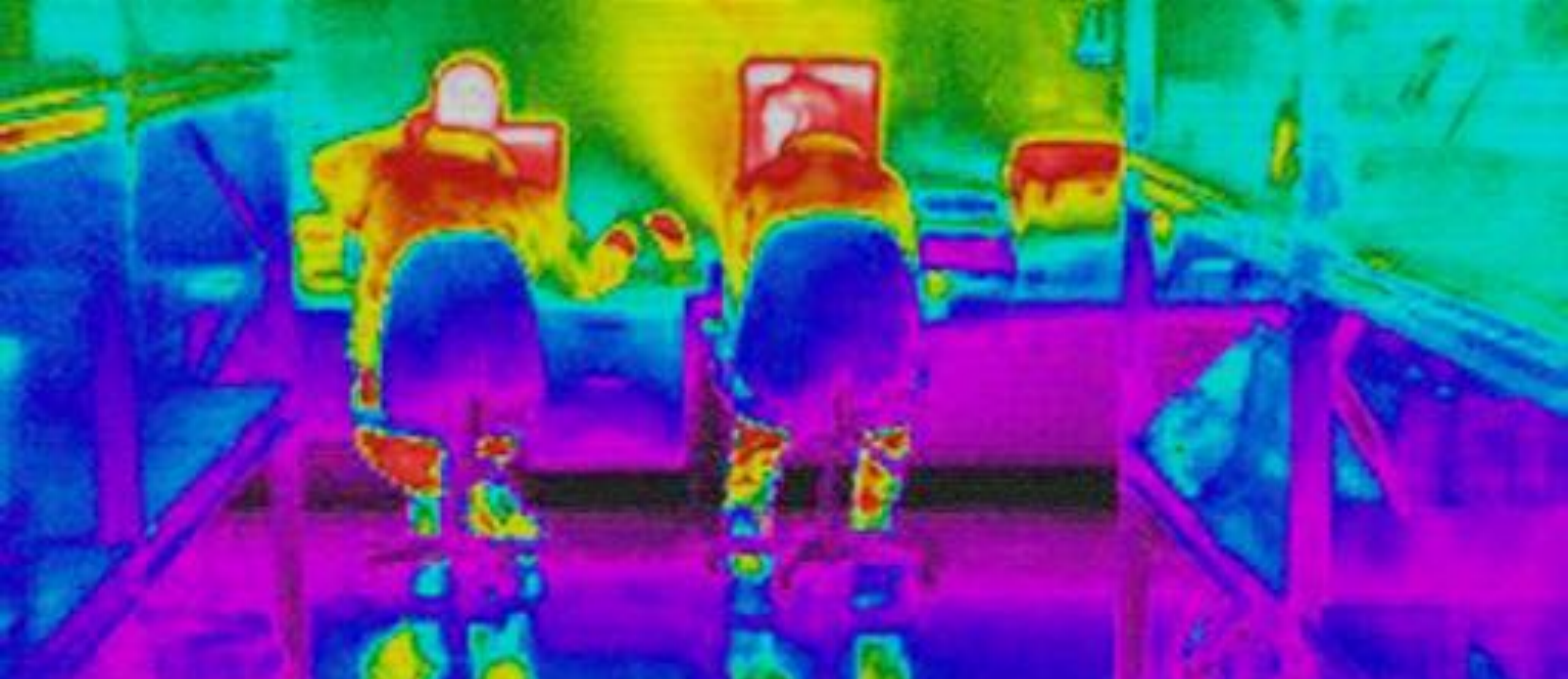

Radiative

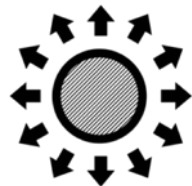

Convective

All in all, its just heat transfer through the wall

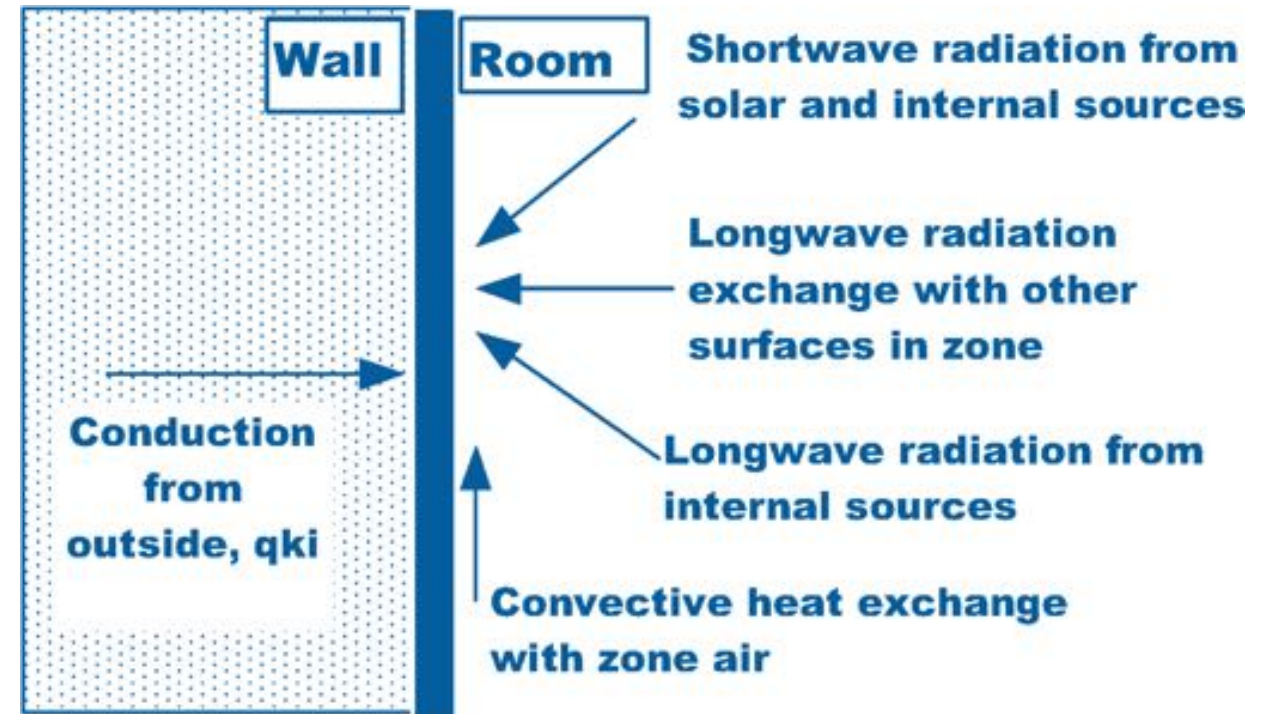
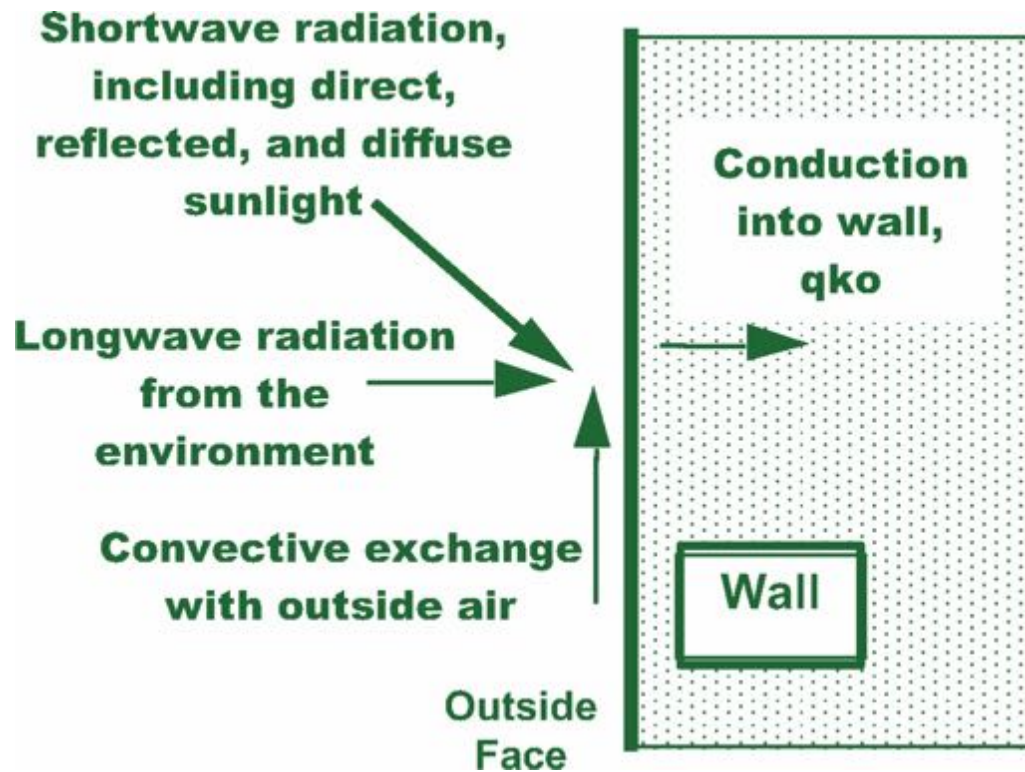

One layer slab: 3R2C

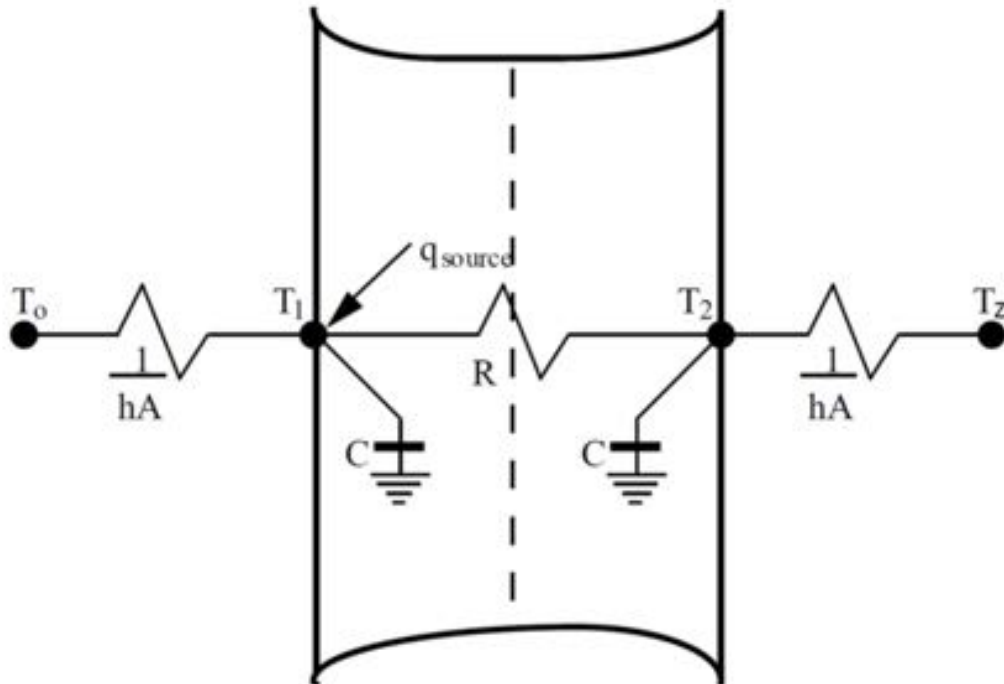

One layer slab:

- **Two interior nodes**, for each surface
 - T_1, T_2
- Convection on both sides.
 - T_o, T_z

Assumptions

- Air inside is well mixed.
- One dimensional heat transfer is assumed for the walls and surfaces..
 - No lateral temperature differences.

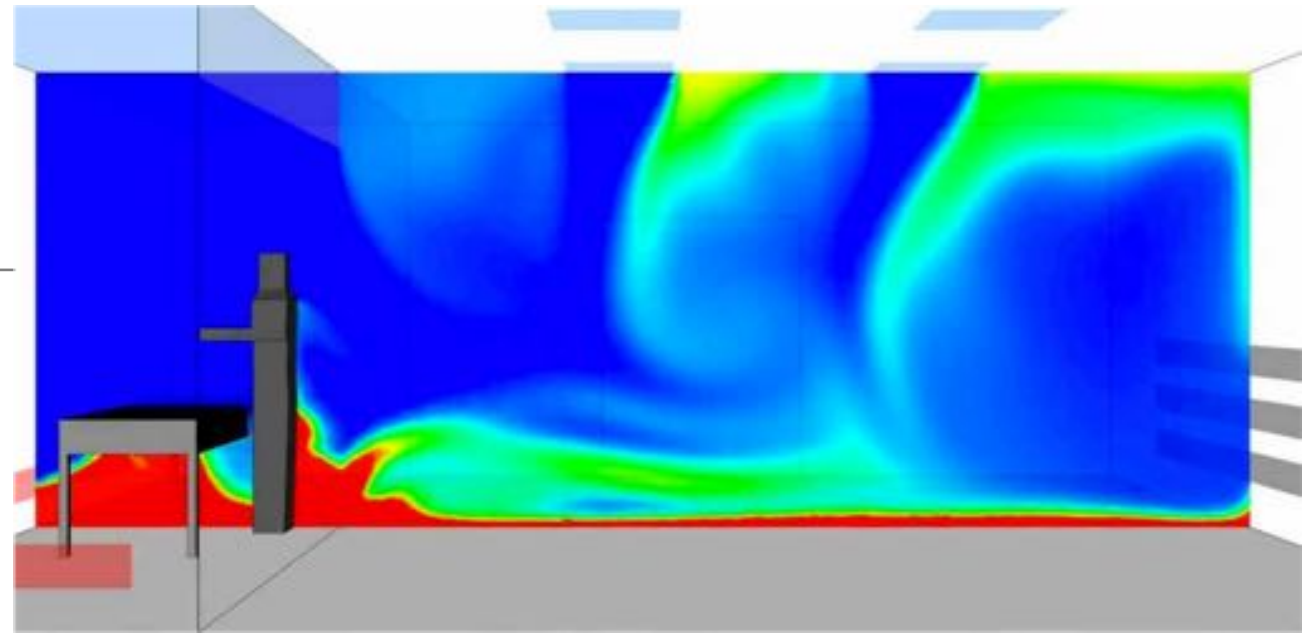

Assumptions

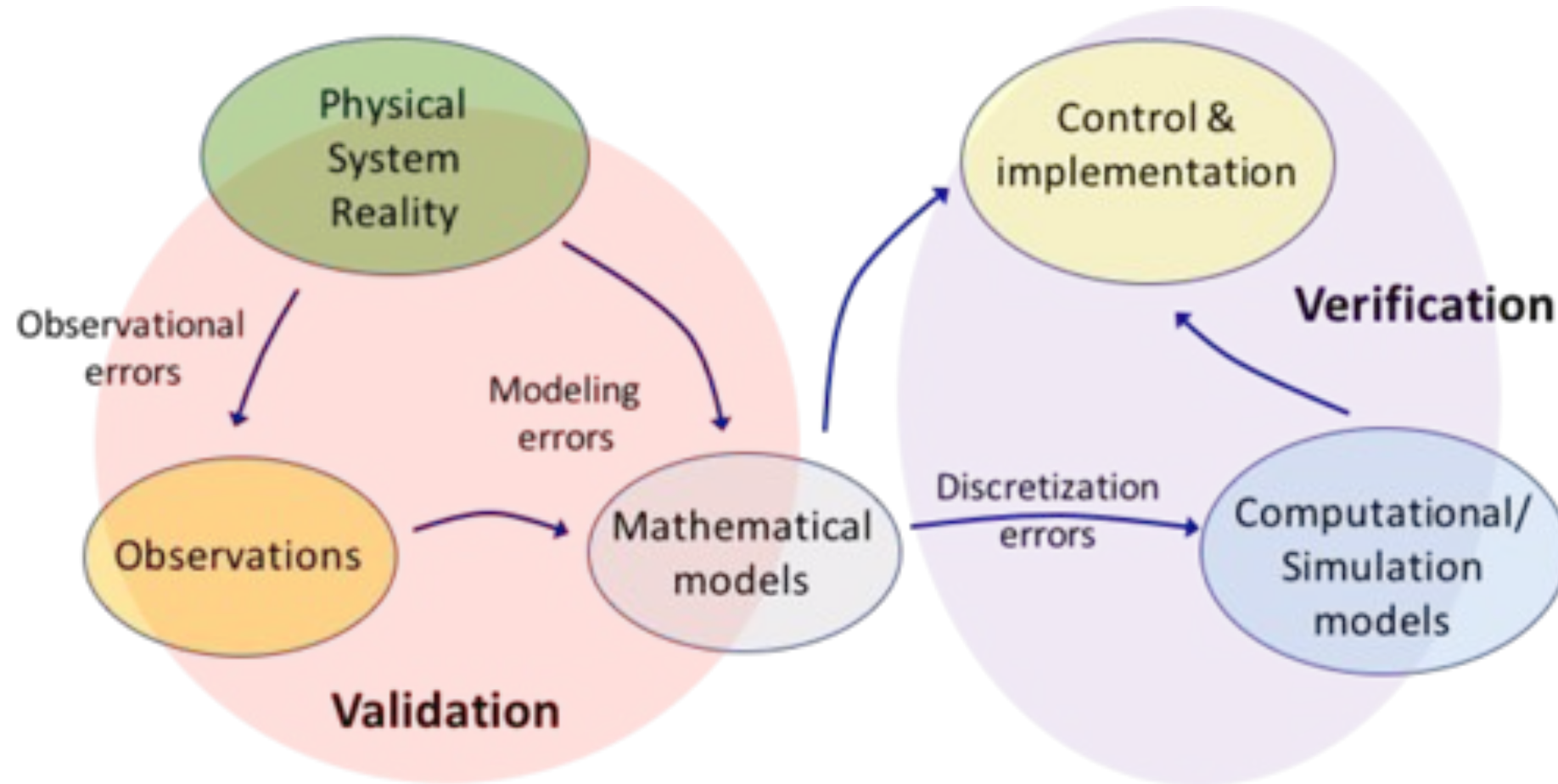

One layer slab: 3R2C

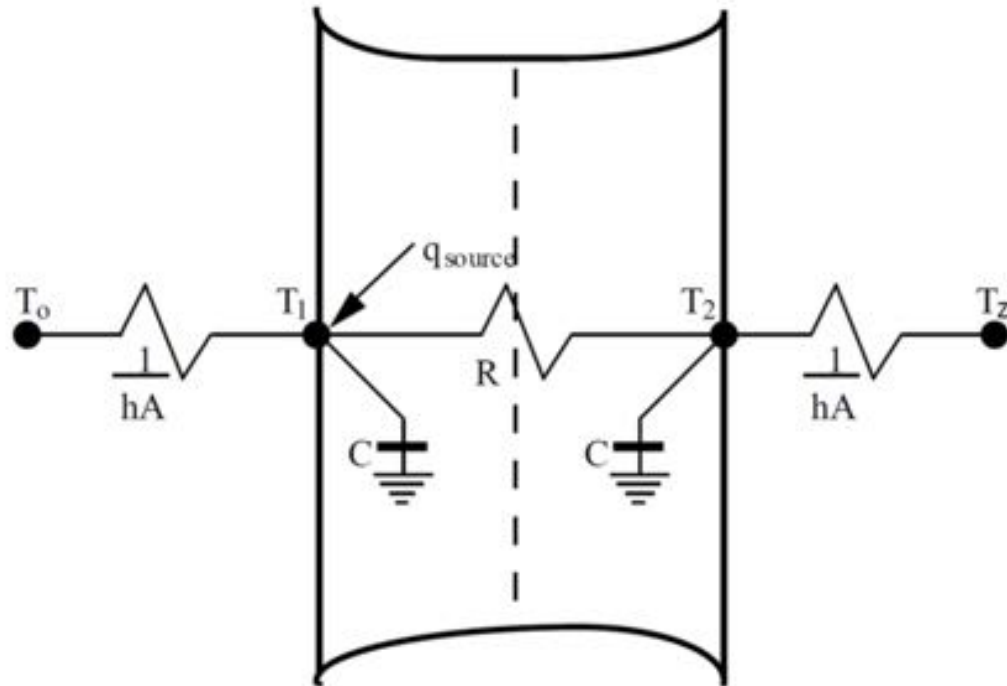

Why are resistors, capacitors, and temperature elements floating and not grounded in this diagram ?

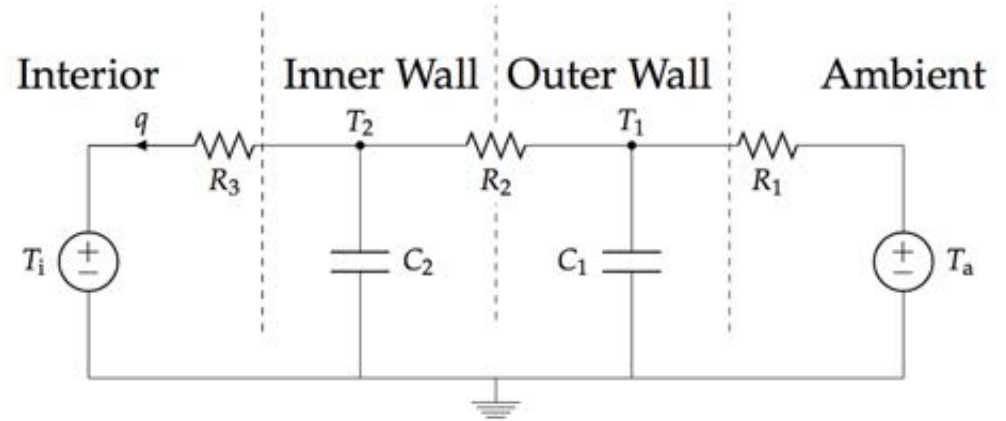

Its convenient

One layer slab: 3R2C

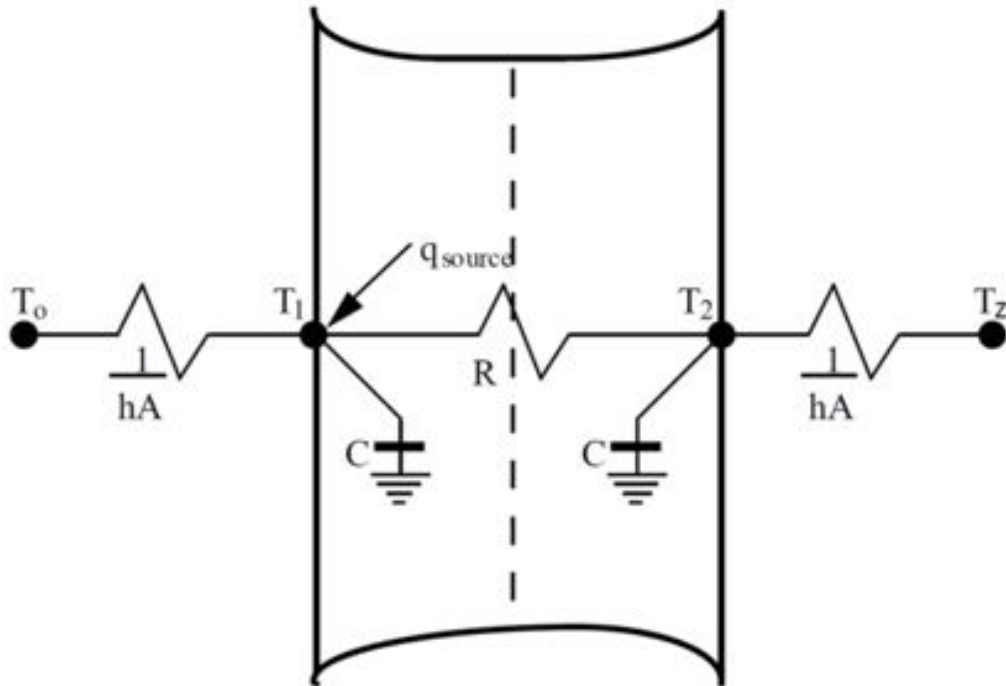

$$C \frac{dT_1}{dt} = hA(T_o - T_1) + \frac{T_2 - T_1}{R} + q_{source}A$$

$$C \frac{dT_2}{dt} = hA(T_z - T_2) + \frac{T_1 - T_2}{R}$$

$$R = \frac{\ell}{kA},$$

$$C = \frac{\rho c_p \ell A}{2}$$

q_{source} : Heat flux, W/m²
e.g. solar irradiance

3R2C – A closer look

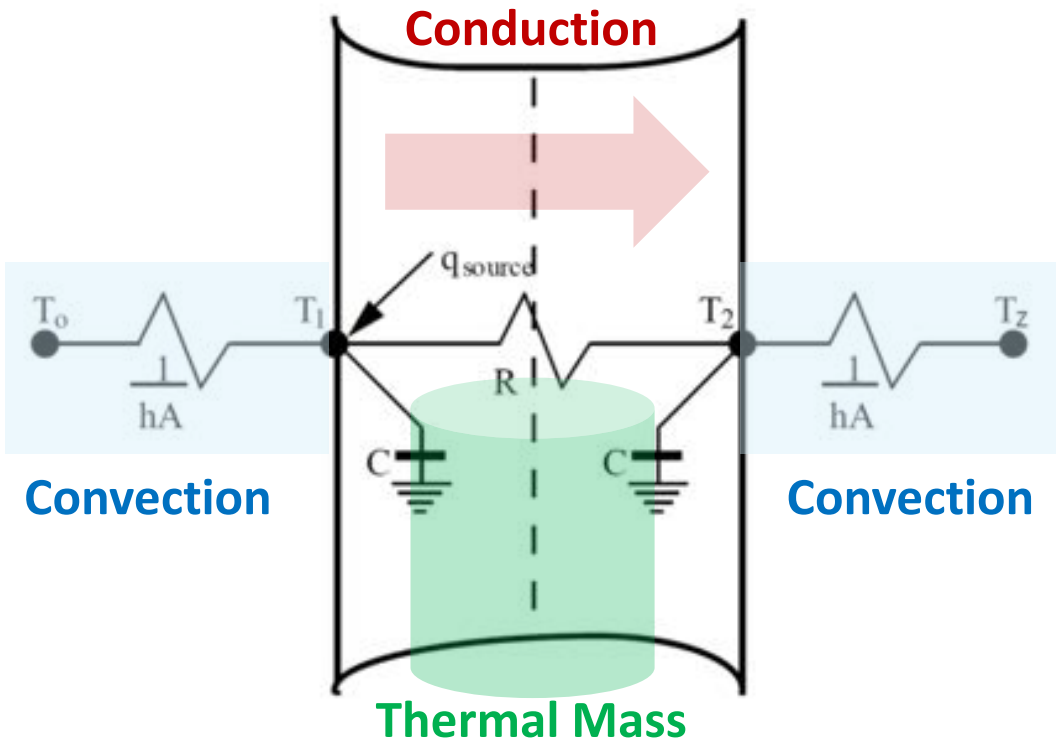

$$\begin{aligned}
 C \frac{dT_1}{dt} &= hA(T_o - T_1) + \frac{T_2 - T_1}{R} + q_{source}A \\
 C \frac{dT_2}{dt} &= hA(T_z - T_2) + \frac{T_1 - T_2}{R}
 \end{aligned}$$

Thermal Mass Convection Conduction

Announcements

- Install EnergyPlus before the next lecture on Thursday, September 20.
 - <https://energyplus.net/>
 - Whole building energy simulator



- Optional:
 - Create an account at <https://usonialabs.com/>

Assignment 2 is out

- Thermal RC modeling for a single zone.
- Due in 1 week: Tuesday, Sep 25 at 2:00pm
- No programming parts
- If you are submitting an electronic copy on collab:
 - Upload a single PDF file only.
 - Use the following filename format: <FirstName_LastName_UVA-ID>.pdf

Zone temperature dynamics

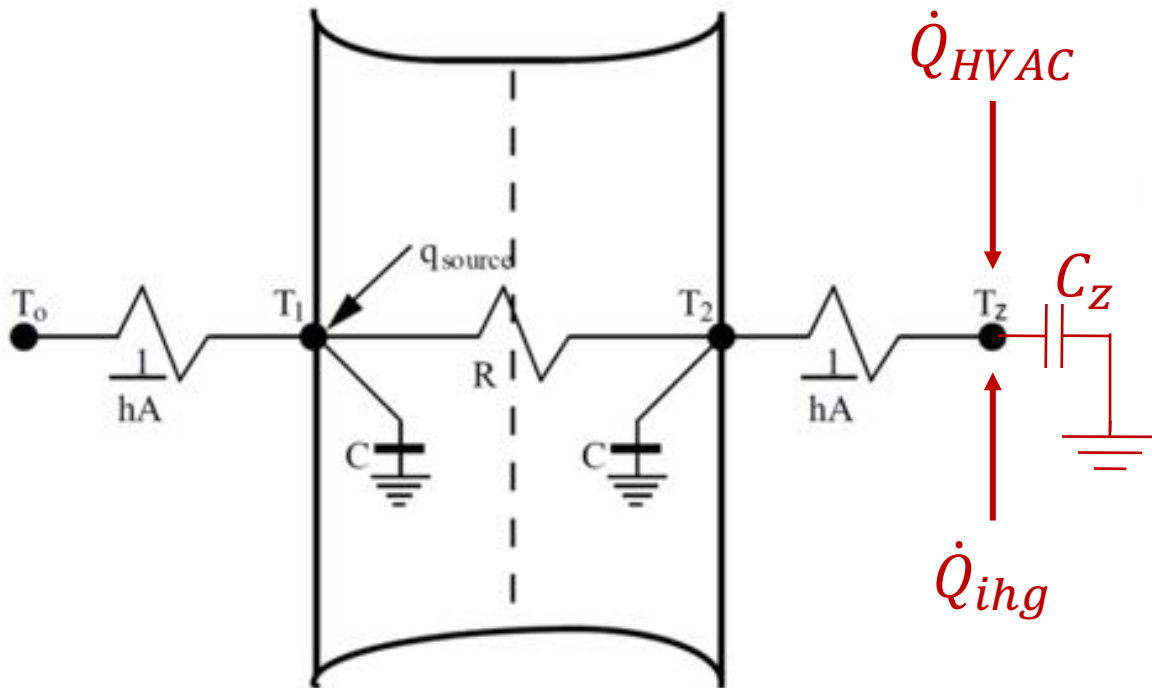

$$C \frac{dT_1}{dt} = hA(T_o - T_1) + \frac{T_2 - T_1}{R} + q_{source}A$$

$$C \frac{dT_2}{dt} = hA(T_z - T_2) + \frac{T_1 - T_2}{R}$$

$$C_z \frac{dT_z}{dt} = hA(T_2 - T_z) + \dot{Q}_{inh} + \dot{Q}_{HVAC}$$

Zone temperature dynamics

$$C \frac{dT_1}{dt} = hA(T_o - T_1) + \frac{T_2 - T_1}{R} + q_{source}A$$
$$C \frac{dT_2}{dt} = hA(T_z - T_2) + \frac{T_1 - T_2}{R}$$

$$C_z \frac{dT_z}{dt} = hA(T_2 - T_z) + \dot{Q}_{ihg} + \dot{Q}_{HVAC}$$

States: T_1, T_2, T_z

Parameters (unknown)

Inputs: $T_o, q_{source}A, \dot{Q}_{ihg}, \dot{Q}_{HVAC}$

h, R, A, C, C_z

State-Space dynamics

$$C \frac{dT_1}{dt} = hA(T_o - T_1) + \frac{T_2 - T_1}{R} + q_{source}A$$

$$C \frac{dT_2}{dt} = hA(T_z - T_2) + \frac{T_1 - T_2}{R}$$

$$C_z \frac{dT_z}{dt} = hA(T_2 - T_z) + \dot{Q}_{ihg} + \dot{Q}_{HVAC}$$

$$\begin{bmatrix} \dot{T}_1 \\ \dot{T}_2 \\ \dot{T}_z \end{bmatrix} = \begin{bmatrix} \frac{-hA}{C} & \frac{1}{RC} & 0 \\ \frac{1}{RC} & \frac{-hA}{C} & \frac{1}{RC} \\ 0 & \frac{hA}{C_z} & \frac{-hA}{C_z} \end{bmatrix} \begin{bmatrix} T_1 \\ T_2 \\ T_z \end{bmatrix} + \begin{bmatrix} \frac{hA}{C} & \frac{1}{C} & 0 & 0 \\ 0 & 0 & 0 & 0 \\ 0 & 0 & \frac{1}{C_z} & \frac{1}{C_z} \end{bmatrix} \begin{bmatrix} T_o \\ q_{source}A \\ \dot{Q}_{ihg} \\ \dot{Q}_{HVAC} \end{bmatrix}$$

State-Space dynamics

Which variables are changing with time?

$$\dot{x} = Ax + Bu$$

$$\begin{bmatrix} \dot{T}_1 \\ \dot{T}_2 \\ \dot{T}_z \end{bmatrix} = \begin{bmatrix} \frac{-hA}{C} & \frac{1}{RC} & \frac{1}{RC} & 0 \\ \frac{1}{RC} & \frac{-hA}{C} & \frac{1}{RC} & \frac{hA}{RC} \\ 0 & \frac{hA}{C_z} & \frac{-hA}{C_z} & \frac{-hA}{C_z} \end{bmatrix} \begin{bmatrix} T_1 \\ T_2 \\ T_z \end{bmatrix} + \begin{bmatrix} \frac{hA}{C} & \frac{1}{C} & 0 & 0 \\ 0 & 0 & 0 & 0 \\ 0 & 0 & \frac{1}{C_z} & \frac{1}{C_z} \end{bmatrix} \begin{bmatrix} T_0 \\ q_{source}A \\ \dot{Q}_{inhg} \\ \dot{Q}_{HVAC} \end{bmatrix}$$

State-Space dynamics

Is this system LTI ?

$$\dot{x}(t) = Ax(t) + Bu(t)$$

$$\begin{bmatrix} \dot{T}_1(t) \\ \dot{T}_2(t) \\ \dot{T}_z(t) \end{bmatrix} = \begin{bmatrix} \frac{-hA}{C} & \frac{1}{RC} & \frac{1}{RC} & 0 \\ \frac{1}{RC} & \frac{-hA}{C} & \frac{1}{RC} & \frac{hA}{RC} \\ 0 & \frac{hA}{C_z} & \frac{-hA}{C_z} & \frac{hA}{C_z} \end{bmatrix} \begin{bmatrix} T_1(t) \\ T_2(t) \\ T_z(t) \end{bmatrix} + \begin{bmatrix} \frac{hA}{C} & \frac{1}{C} & 0 & 0 \\ 0 & 0 & 0 & 0 \\ 0 & 0 & \frac{1}{C_z} & \frac{1}{C_z} \end{bmatrix} \begin{bmatrix} T_0(t) \\ q_{source}(t)A \\ \dot{Q}_{ihg}(t) \\ \dot{Q}_{HVAC}(t) \end{bmatrix}$$

Output equation

$$y(t) = Cx(t) + Du(t)$$

$$T_z(t) = [0 \ 0 \ 1] \begin{bmatrix} T_1(t) \\ T_2(t) \\ T_z(t) \end{bmatrix} + [0] \begin{bmatrix} T_0(t) \\ q_{source}(t)A \\ \dot{Q}_{ihg}(t) \\ \dot{Q}_{HVAC}(t) \end{bmatrix}$$

To model a single zone:

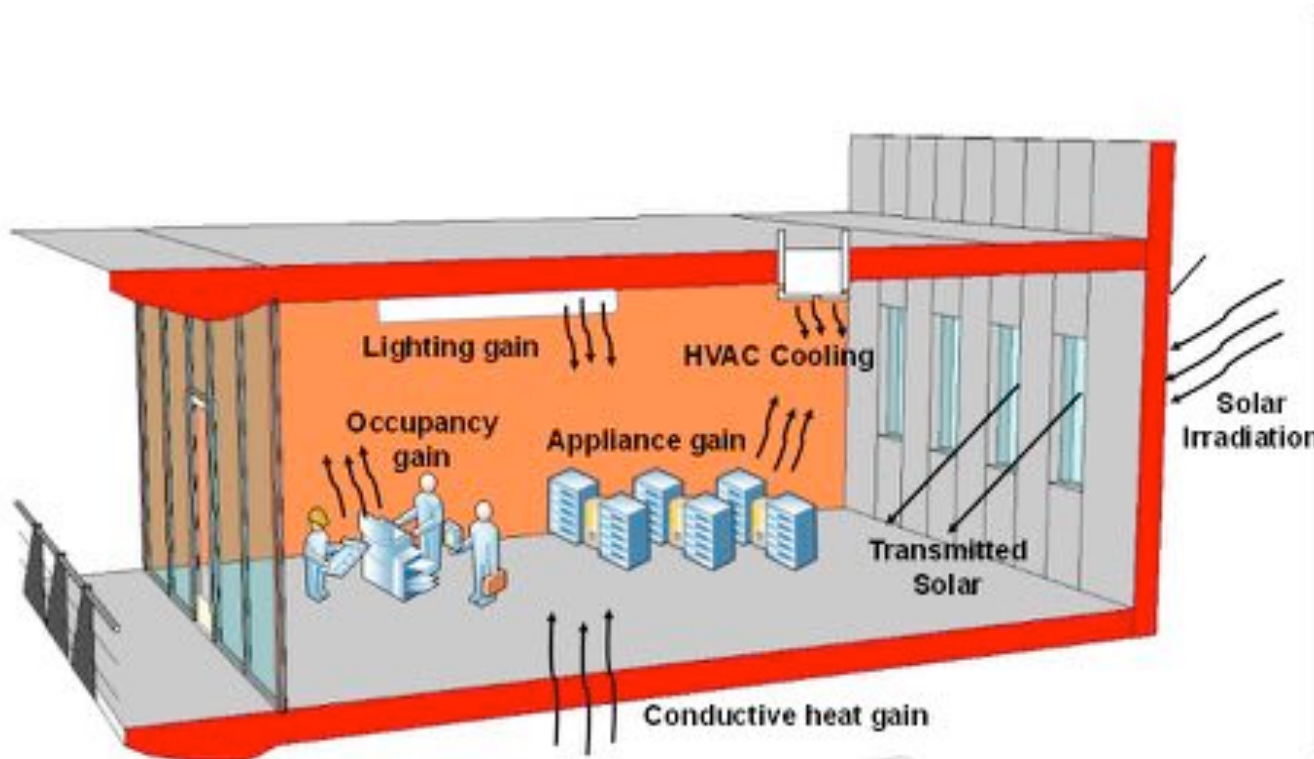

Great!, I know how to model an external wall.
(external because, the outside boundary was ambient temperature)

But what about
Floor,
Ceiling,
Windows,
Other 'internal' walls

To model a single zone:

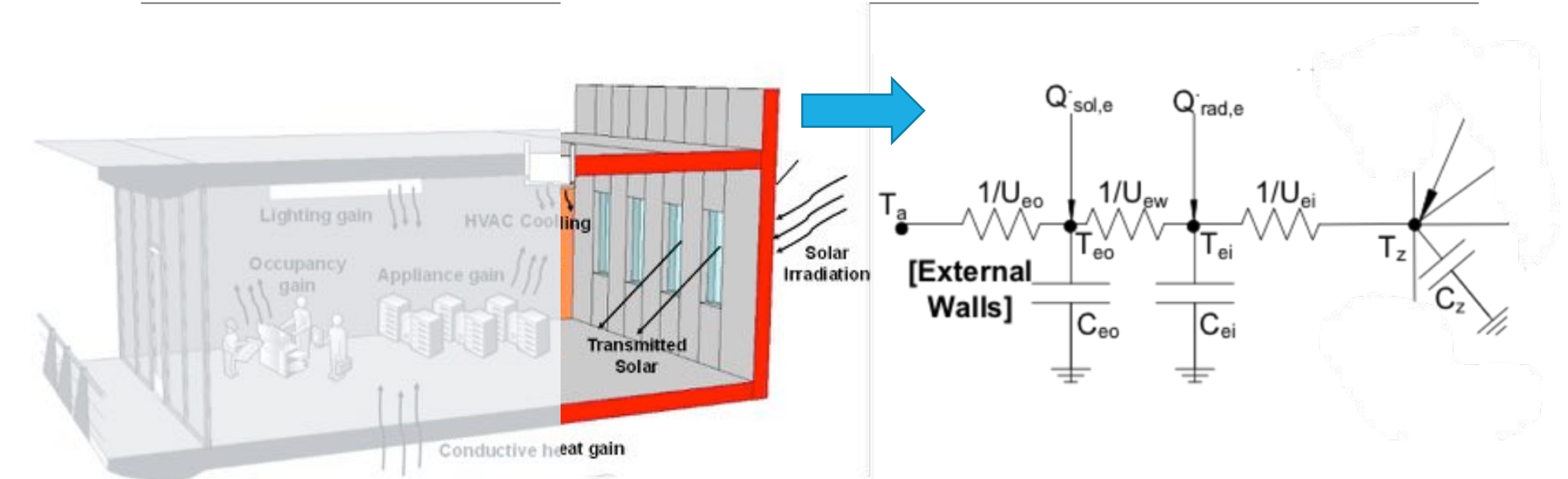

External Wall : Convenient notations

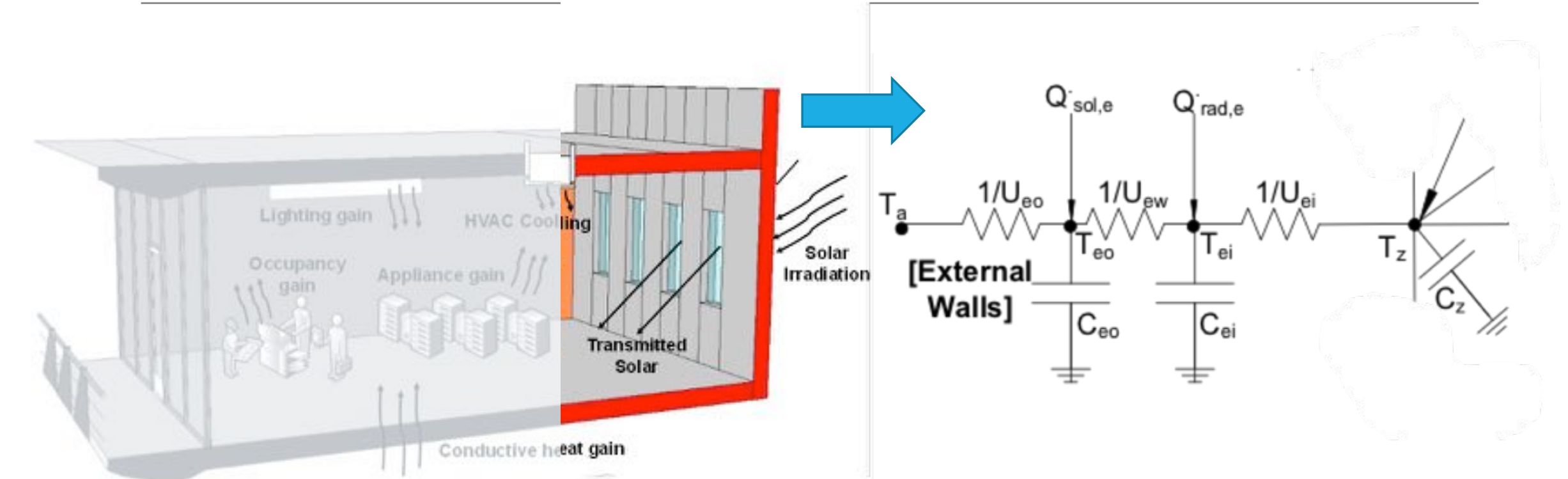

$$R_{thermal\ resistance} = \frac{1}{U_{thermal\ conduction}}$$

$$R_{convective\ resistance} = \frac{1}{hA} = \frac{1}{U_{convective\ conduction}}$$

External Wall : Convenient notations

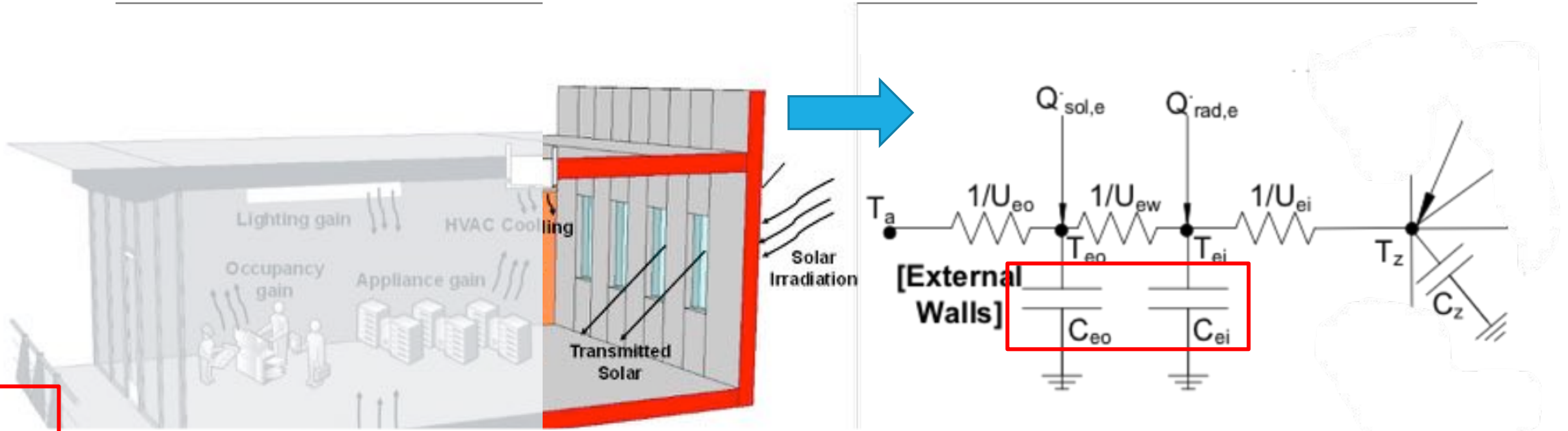

$$C_{eo} \dot{T}_{eo}(t) = U_{eo}(T_a(t) - T_{eo}(t)) + U_{ew}(T_{ei}(t) - T_{eo}(t)) + \dot{Q}_{sol,e}(t)$$

$$C_{ei} \dot{T}_{ei}(t) = U_{ew}(T_{eo}(t) - T_{ei}(t)) + U_{ei}(T_z(t) - T_{ei}(t)) + \dot{Q}_{rad,e}(t)$$

Ceilings – from a modeling perspective

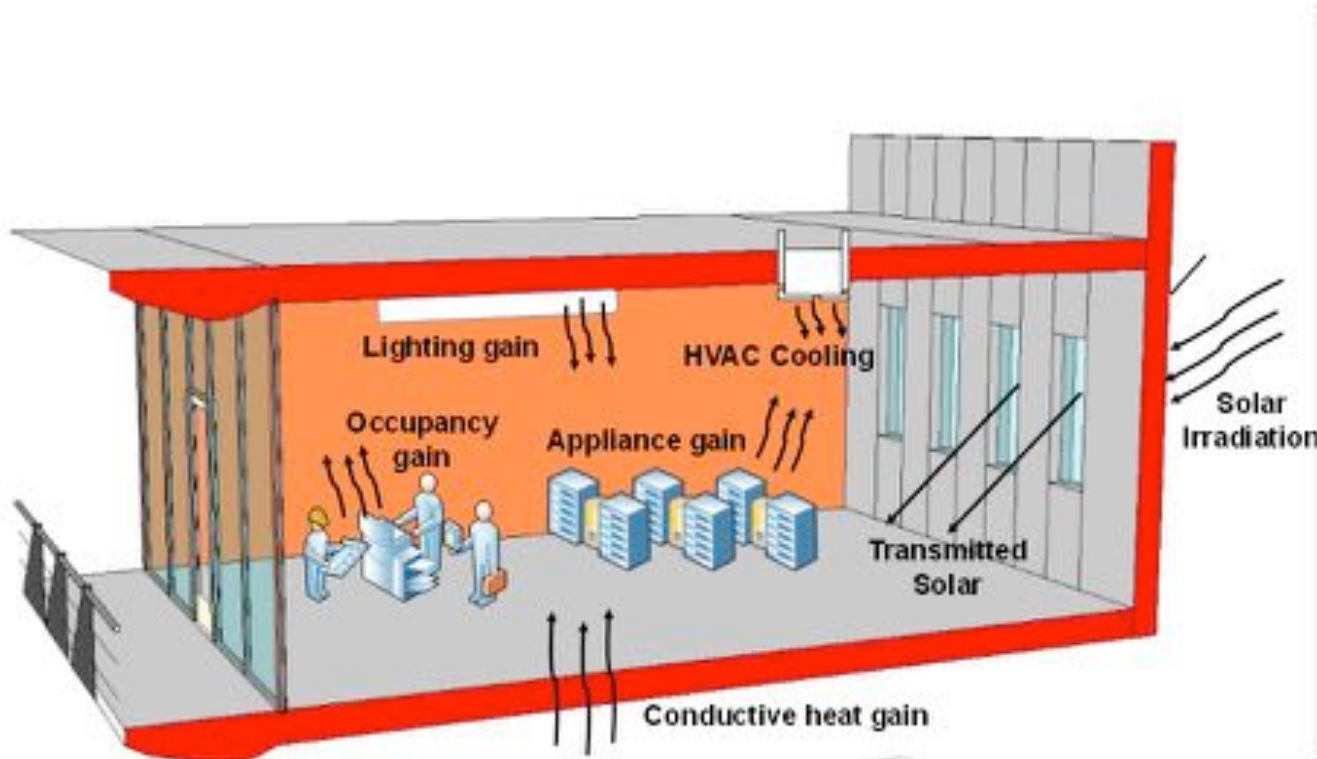

“We are walls too”

- Ceilings
(since forever)

“..so are we..”

- Floors

Ceilings (..floors..internal walls..)

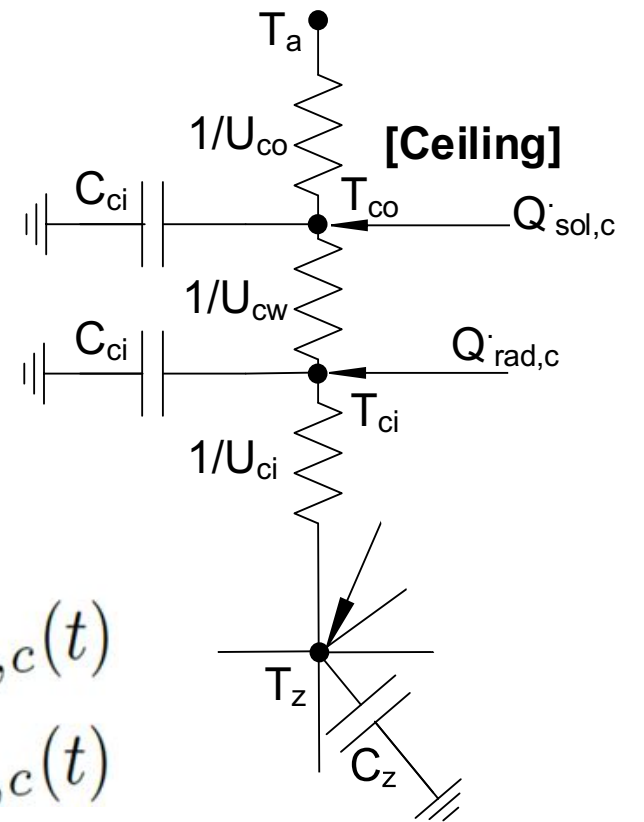
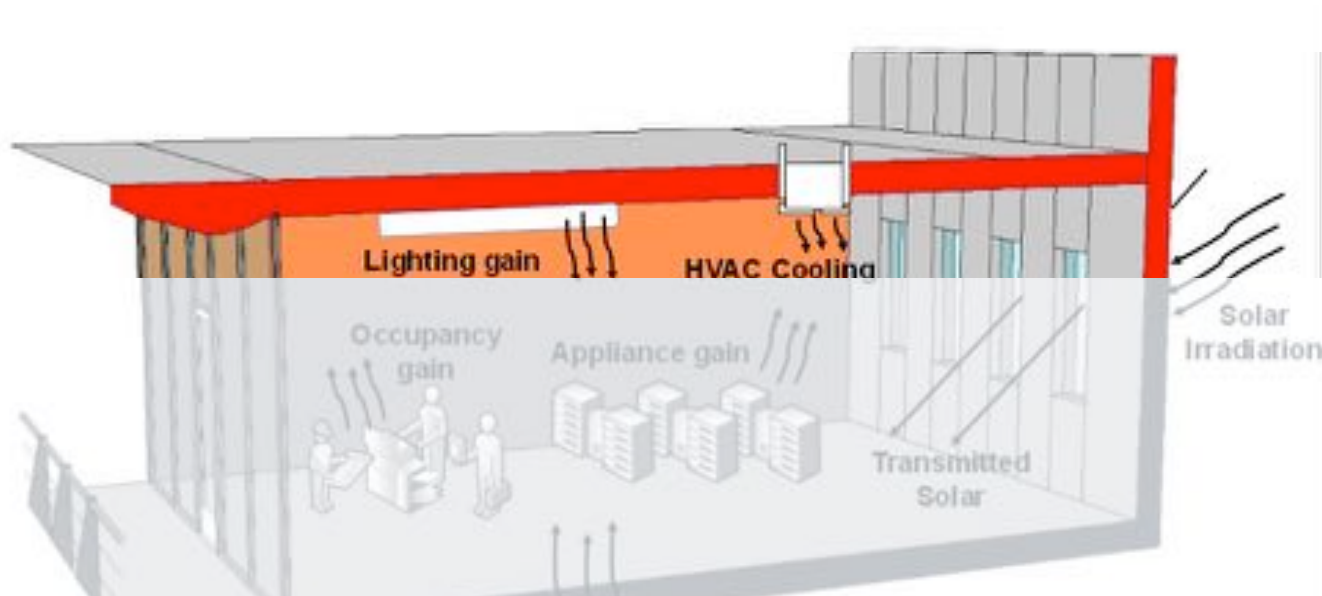

$$C_{co} \dot{T}_{co}(t) = U_{co}(T_a(t) - T_{co}(t)) + U_{cw}(T_{ci}(t) - T_{co}(t)) + \dot{Q}_{sol,c}(t)$$

$$C_{ci} \dot{T}_{ci}(t) = U_{cw}(T_{co}(t) - T_{ci}(t)) + U_{ci}(T_z(t) - T_{ci}(t)) + \dot{Q}_{rad,c}(t)$$

Windows (little to no thermal mass – only thermal resistance)

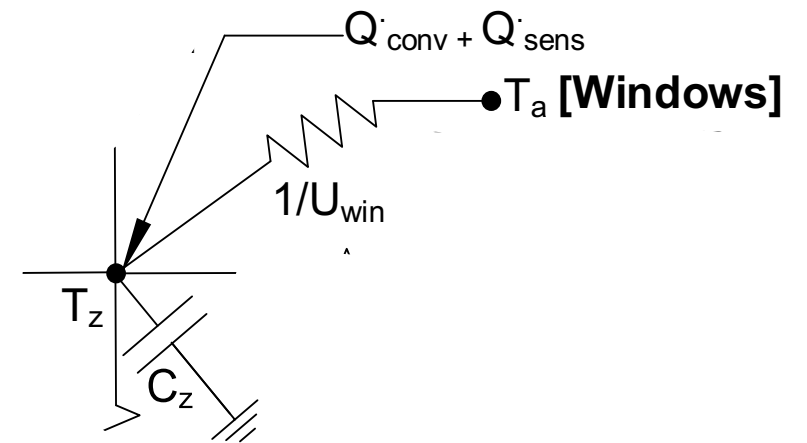
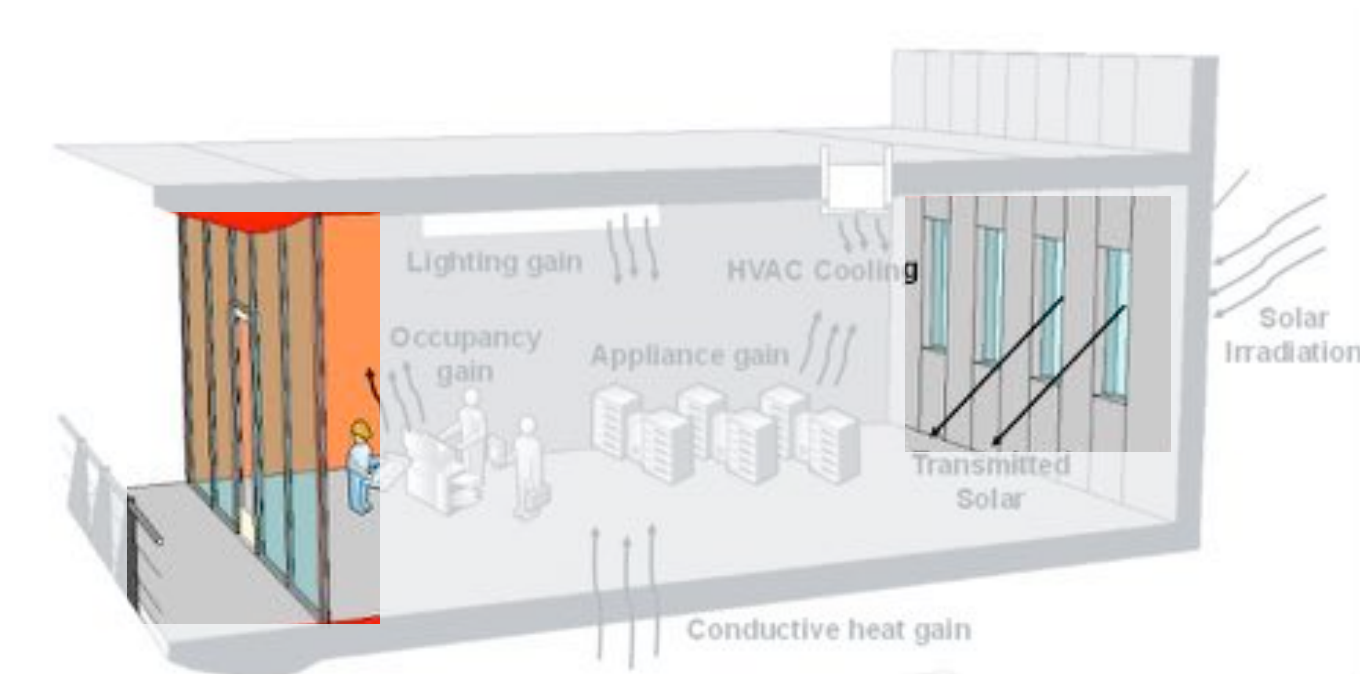

Plenums – from a modeling perspective

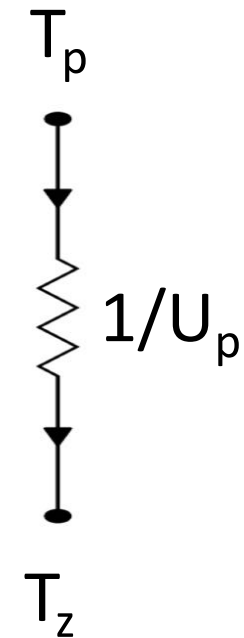
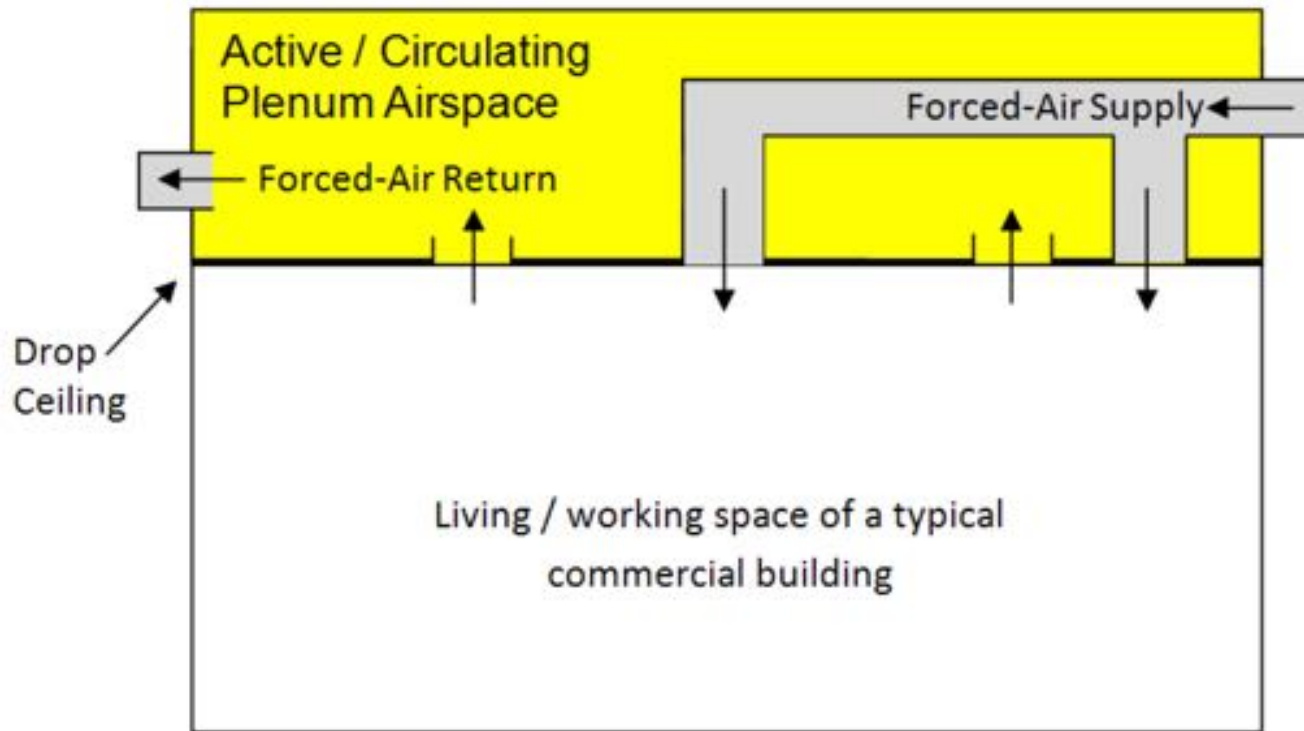

RC modeling methodology

1. All exterior walls are combined into a single exterior wall.
 - a. External boundary condition: Outside air temperature, Incident solar irradiation.
2. Windows/doors (without thermal mass) – Resistive element.
3. Ground and ceiling with appropriate boundary conditions.
 - a. Another zone, ground temperature, outside temperature, plenum.
4. Internal walls for adjacent zones, and/or partitions.
5. Inputs:
 - a. Heat gains to the zone temperature,
 - b. Solar irradiance,
 - c. All boundary temperatures

Gray box modeling: “RC-Networks”

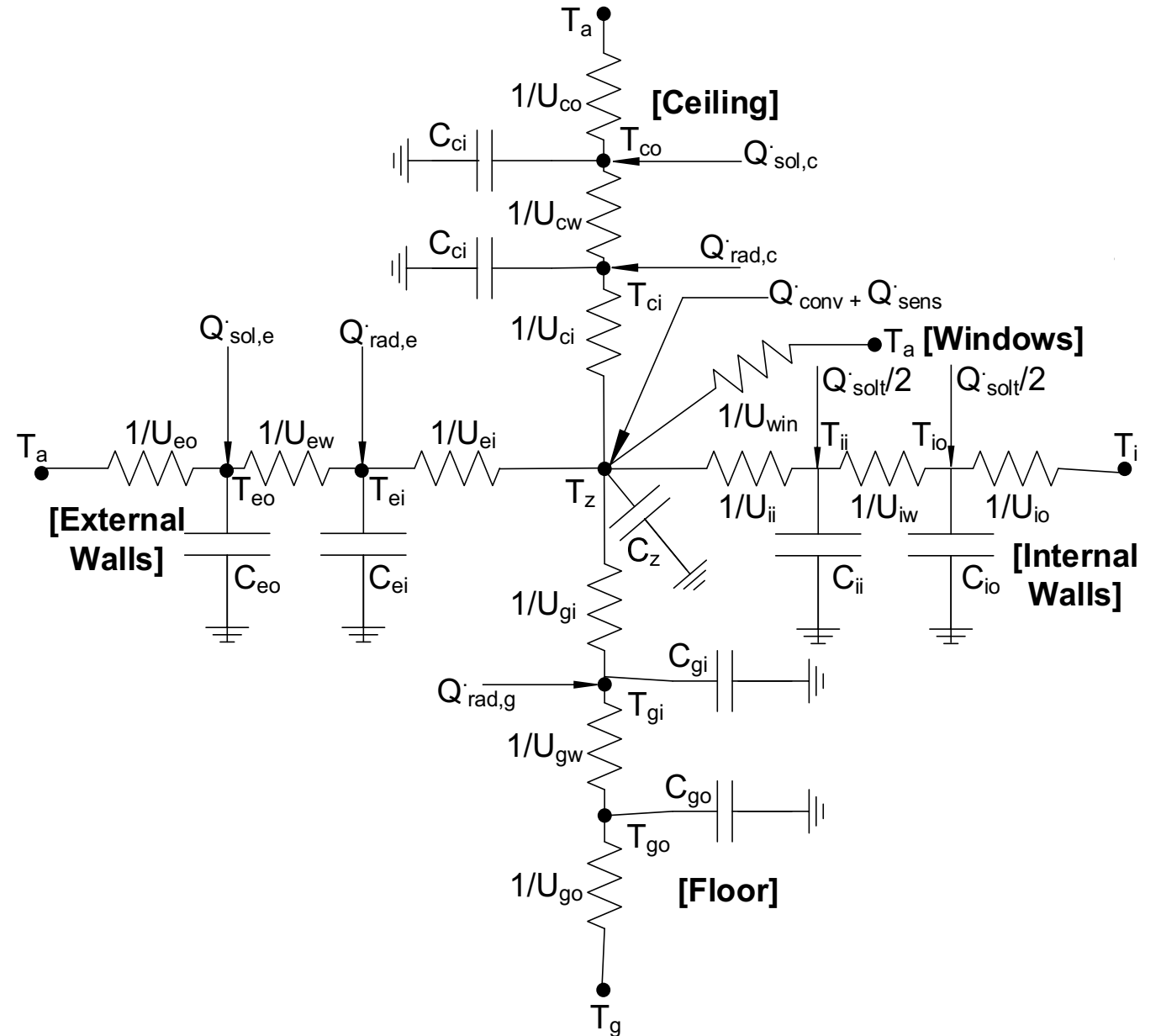

Every surface is a ‘RC’ branch in the network

Every surface is a 'RC' branch in the network

Branch heat balance equations [3R2C]

$$C_{eo} \dot{T}_{eo}(t) = U_{eo}(T_a(t) - T_{eo}(t)) + U_{ew}(T_{ei}(t) - T_{eo}(t)) + \dot{Q}_{sol,e}(t)$$

$$C_{ei} \dot{T}_{ei}(t) = U_{ew}(T_{eo}(t) - T_{ei}(t)) + U_{ei}(T_z(t) - T_{ei}(t)) + \dot{Q}_{rad,e}(t)$$

$$C_{co} \dot{T}_{co}(t) = U_{co}(T_a(t) - T_{co}(t)) + U_{cw}(T_{ci}(t) - T_{co}(t)) + \dot{Q}_{sol,c}(t)$$

$$C_{ci} \dot{T}_{ci}(t) = U_{cw}(T_{co}(t) - T_{ci}(t)) + U_{ci}(T_z(t) - T_{ci}(t)) + \dot{Q}_{rad,c}(t)$$

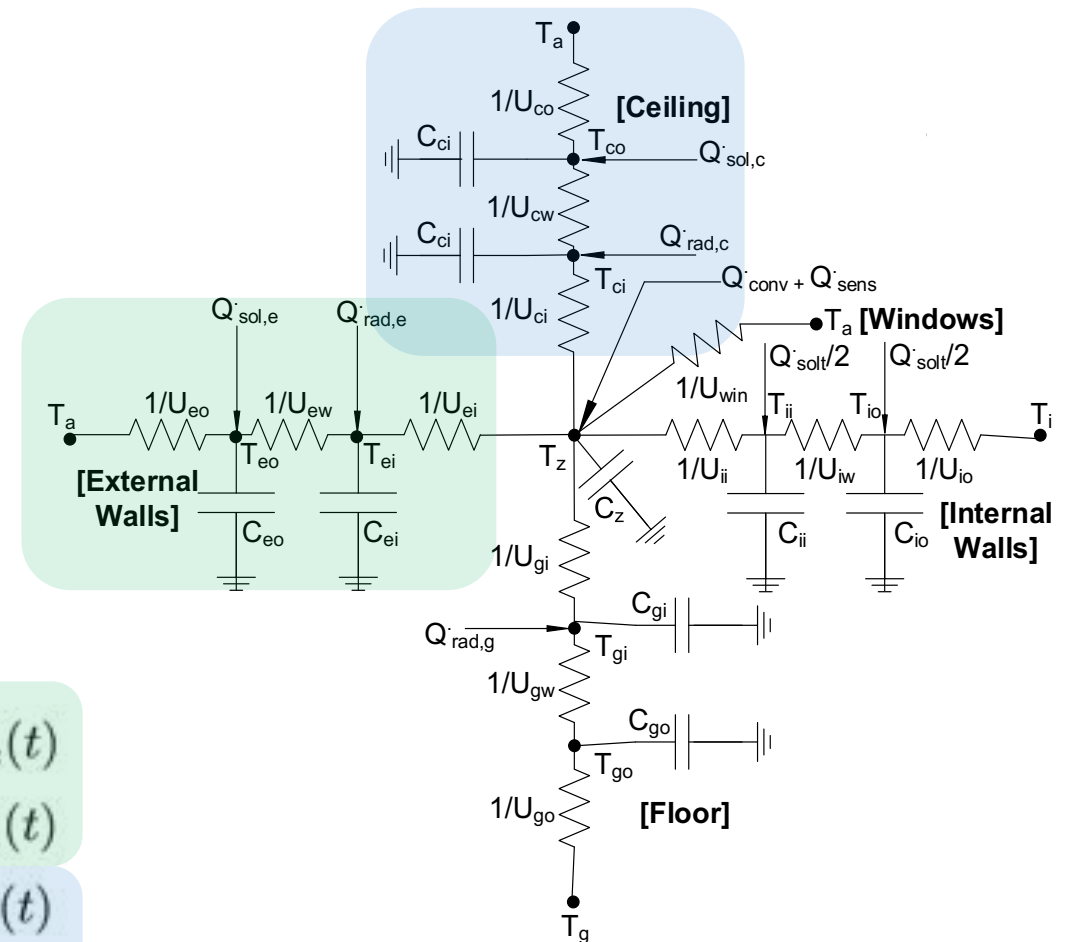

Every surface is a 'RC' branch in the network

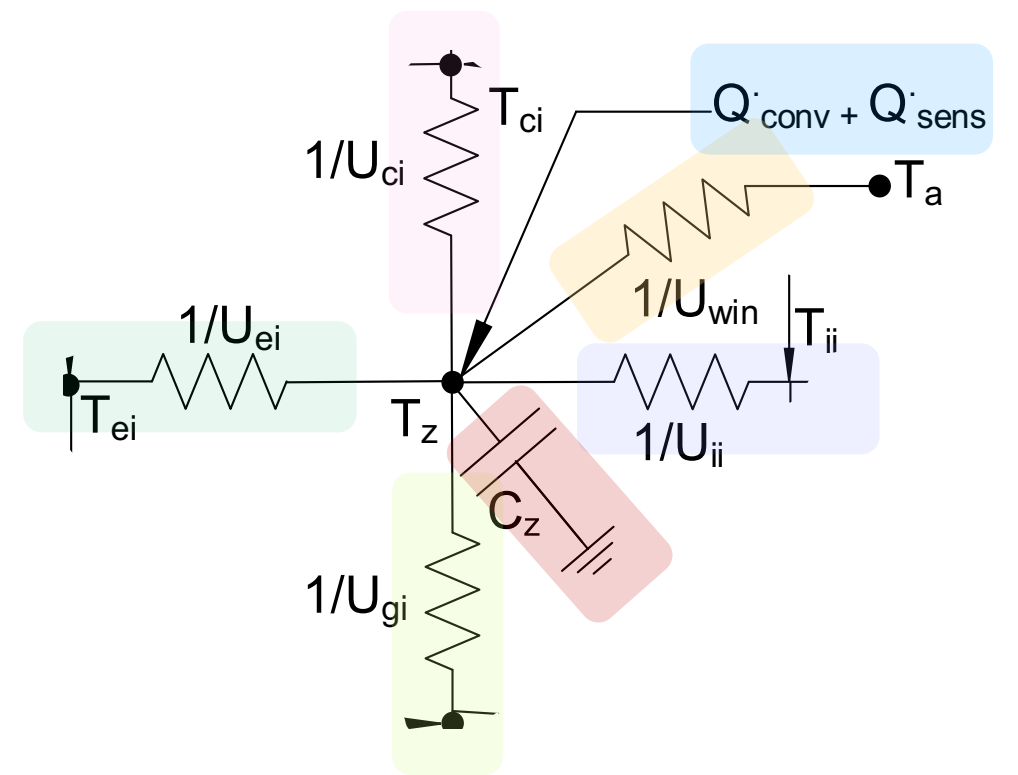

Zone heat balance equation

$$\begin{aligned}
 C_z \dot{T}_z(t) = & \overset{\text{External Wall}}{U_{ei}(T_{ei}(t) - T_z(t))} + \overset{\text{Ceiling}}{U_{ci}(T_{ci}(t) - T_z(t))} \\
 & + \overset{\text{Internal Wall}}{U_{ii}(T_{ii}(t) - T_z(t))} + \overset{\text{Floor}}{U_{gi}(T_{gi}(t) - T_z(t))} \\
 & + \overset{\text{Windows}}{U_{win}(T_a(t) - T_z(t))} + \overset{\text{Heat Gains/Losses}}{\dot{Q}_{conv}(t) + \dot{Q}_{sens}(t)}
 \end{aligned}$$

Zone Air
Thermal
mass

Gray box modeling: "RC-Networks"

All the heat balance equations
Branches + zone temperature



$$\dot{x}(t) = A_{\alpha}x(t) + B_{\alpha}u(t)$$

$$y(t) = C_{\alpha}x(t) + D_{\alpha}u(t)$$

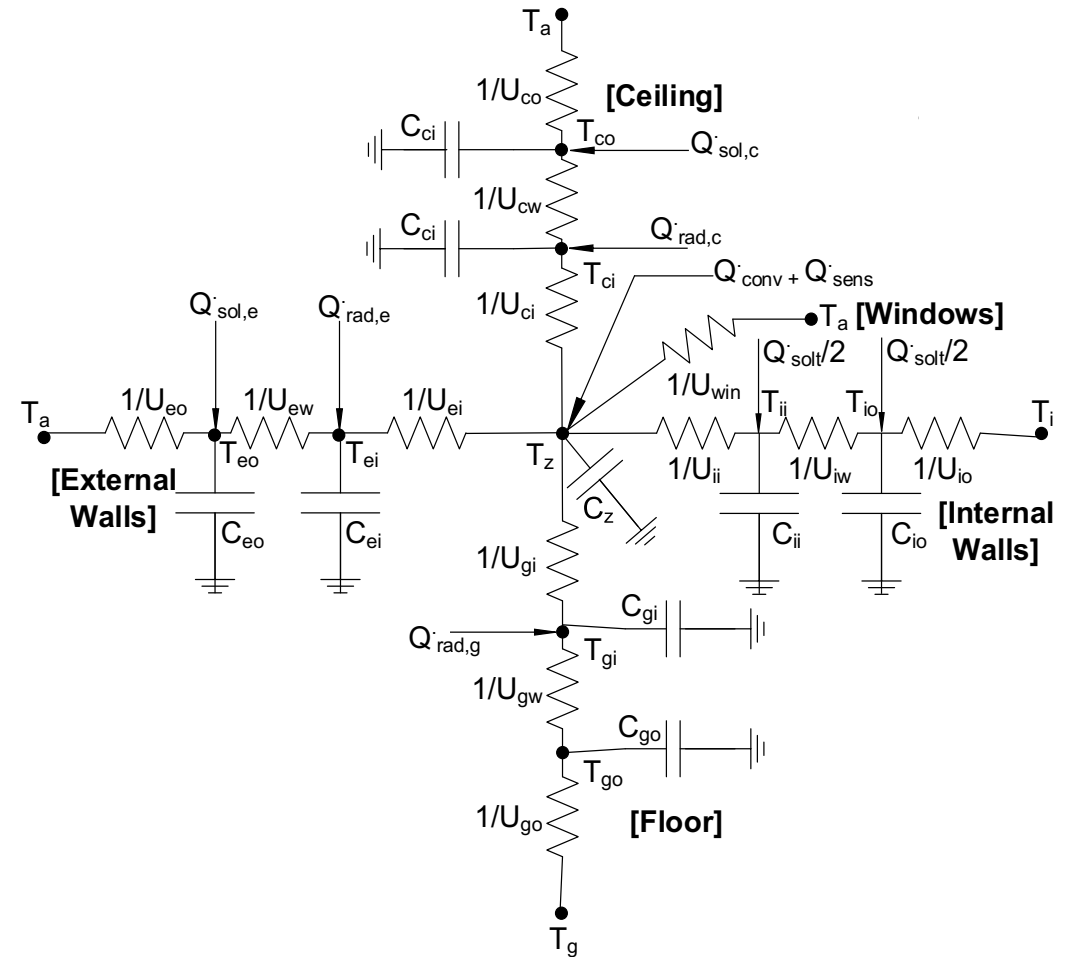

Gray box modeling: "RC-Networks"

States : All nodes of the network except boundary nodes

$$x = [T_{eo}, T_{ei}, T_{co}, T_{ci}, T_{go}, T_{gi}, T_{io}, T_{ii}, T_z]^T$$

Inputs: All boundary conditions and heat gains.

$$u = [T_a, T_g, T_i, \dot{Q}_{sol,e}, \dot{Q}_{sol,c}, \dot{Q}_{rad,e}, \dot{Q}_{rad,c}, \dot{Q}_{rad,g}, \dot{Q}_{solt}, \dot{Q}_{conv}, \dot{Q}_{sens}]^T$$

Parameters: The resistances/conductances and capacitances

$$\alpha = [U_{eo}, U_{ew}, U_{ei}, \dots, C_{io}, C_{ii}]^T$$

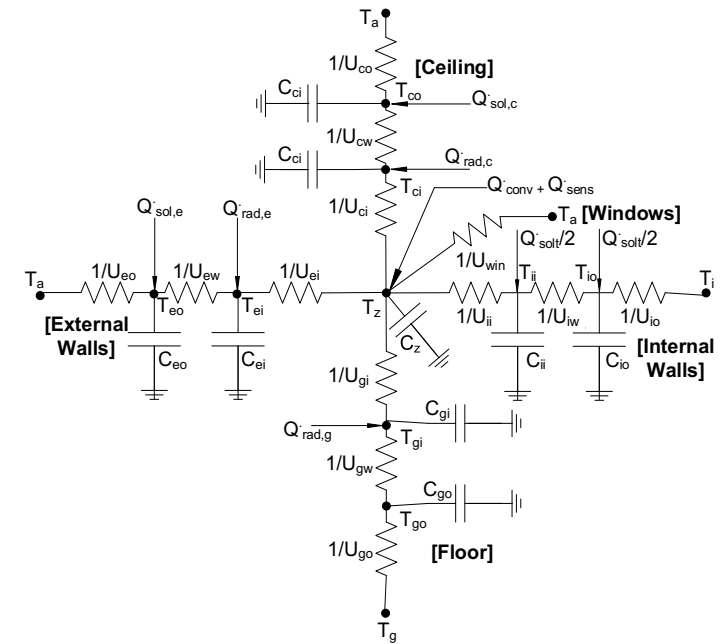

A closer look at the heating/cooling input

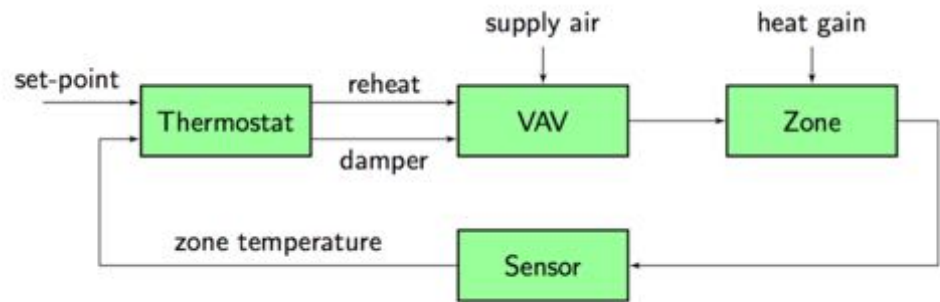

$$\dot{Q}_{sens} = m_{sup} c_{p,air} (T_{sup} - T_{zone})$$

Mass flow rate

Supply air temperature

Assuming return air temperature is the same as zone air temperature.

Zone heat balance equation

$$\begin{aligned} C_z \dot{T}_z(t) = & U_{ei}(T_{ei}(t) - T_z(t)) + U_{ci}(T_{ci}(t) - T_z(t)) \\ & + U_{ii}(T_{ii}(t) - T_z(t)) + U_{gi}(T_{gi}(t) - T_z(t)) \\ & + U_{win}(T_a(t) - T_z(t)) + \dot{Q}_{conv}(t) \\ & + \dot{m}_{sup} c_{p,air} (T_{sup} - T_z) \end{aligned}$$

$$\dot{x} = Ax + Bu$$

Inputs: All boundary conditions and heat gains.

$$u = [T_a, T_g, T_i, \dot{Q}_{sol,e}, \dot{Q}_{sol,c}, \dot{Q}_{rad,e}, \dot{Q}_{rad,c}, \dot{Q}_{rad,g}, \dot{Q}_{solt}, \dot{Q}_{conv}, \dot{m}_{sup}, T_{sup}]^T$$

Zone heat balance equation

$$\begin{aligned} C_z \dot{T}_z(t) = & U_{ei}(T_{ei}(t) - T_z(t)) + U_{ci}(T_{ci}(t) - T_z(t)) \\ & + U_{ii}(T_{ii}(t) - T_z(t)) + U_{gi}(T_{gi}(t) - T_z(t)) \\ & + U_{win}(T_a(t) - T_z(t)) + \dot{Q}_{conv}(t) \\ & + \dot{m}_{sup} c_{p,air} (T_{sup} - T_z) \end{aligned}$$

Model has become non-linear (bi-linear) !

Modeling complexity depends on the purpose

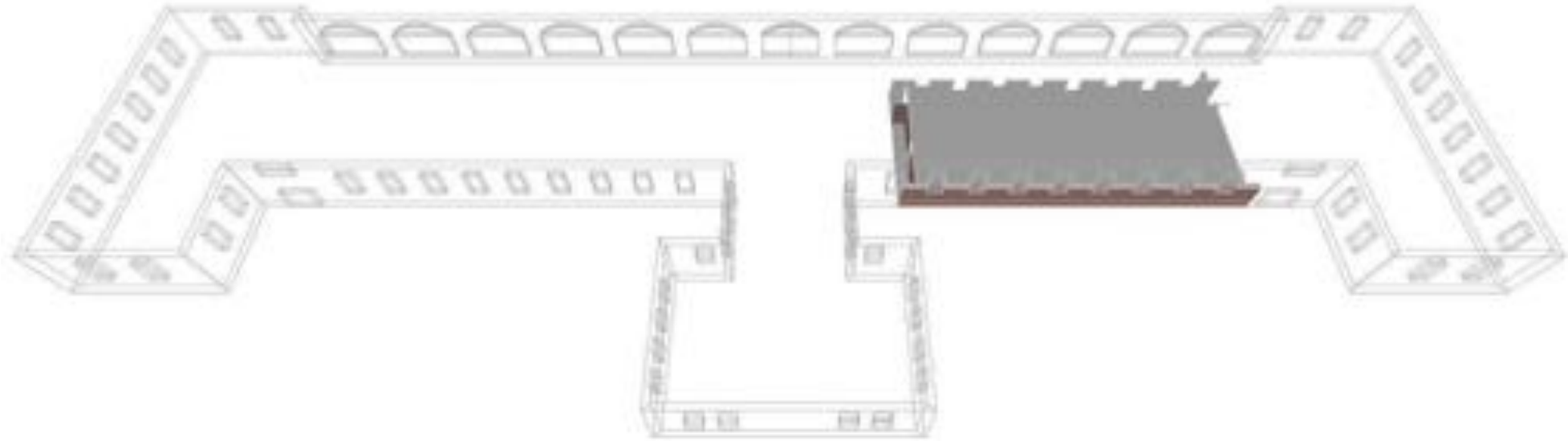

Lets say you had to model this one zone on the second level of the building

Modeling choices

1. Does every internal wall require its own RC branch ?
2. What about windows which maybe the same material but face different directions ?
3. Do doors have thermal mass ?
4. How do you compute the total internal heat gain at any time ?

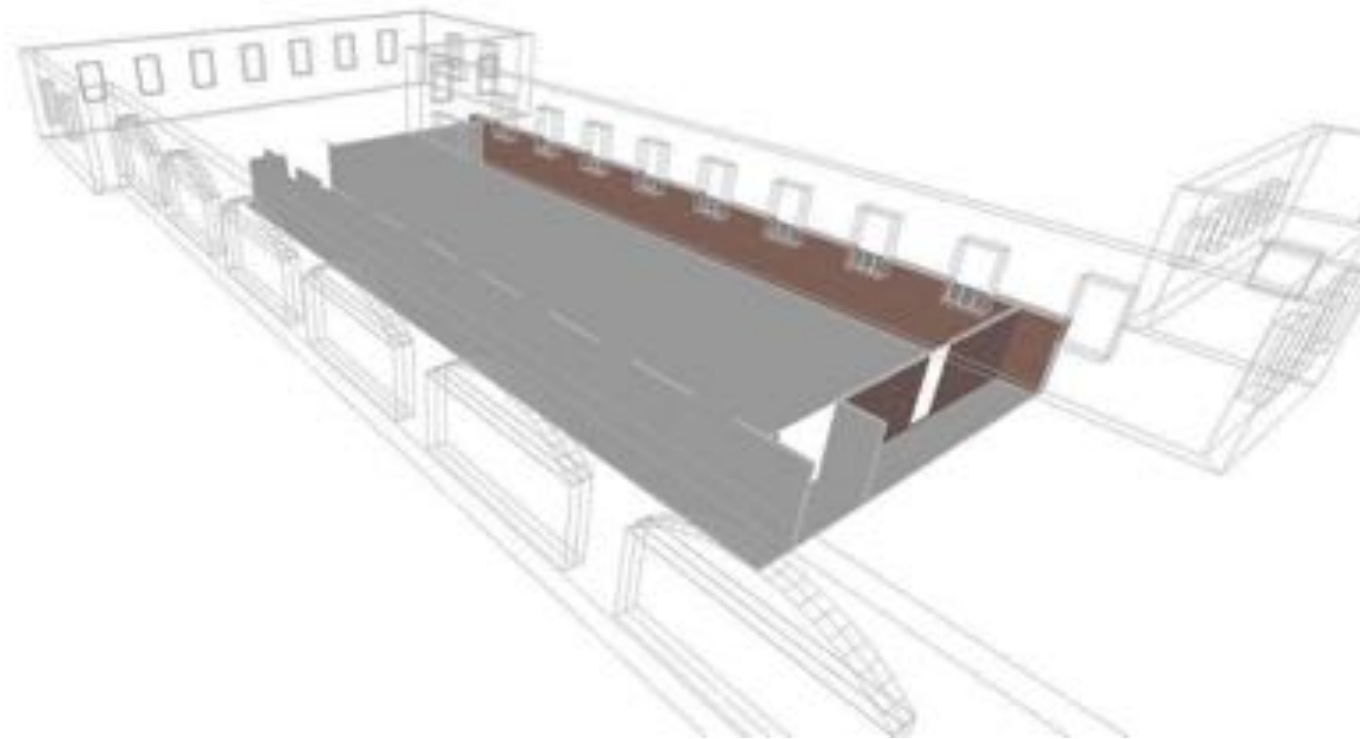

Recall: Single zone: Heat Gains

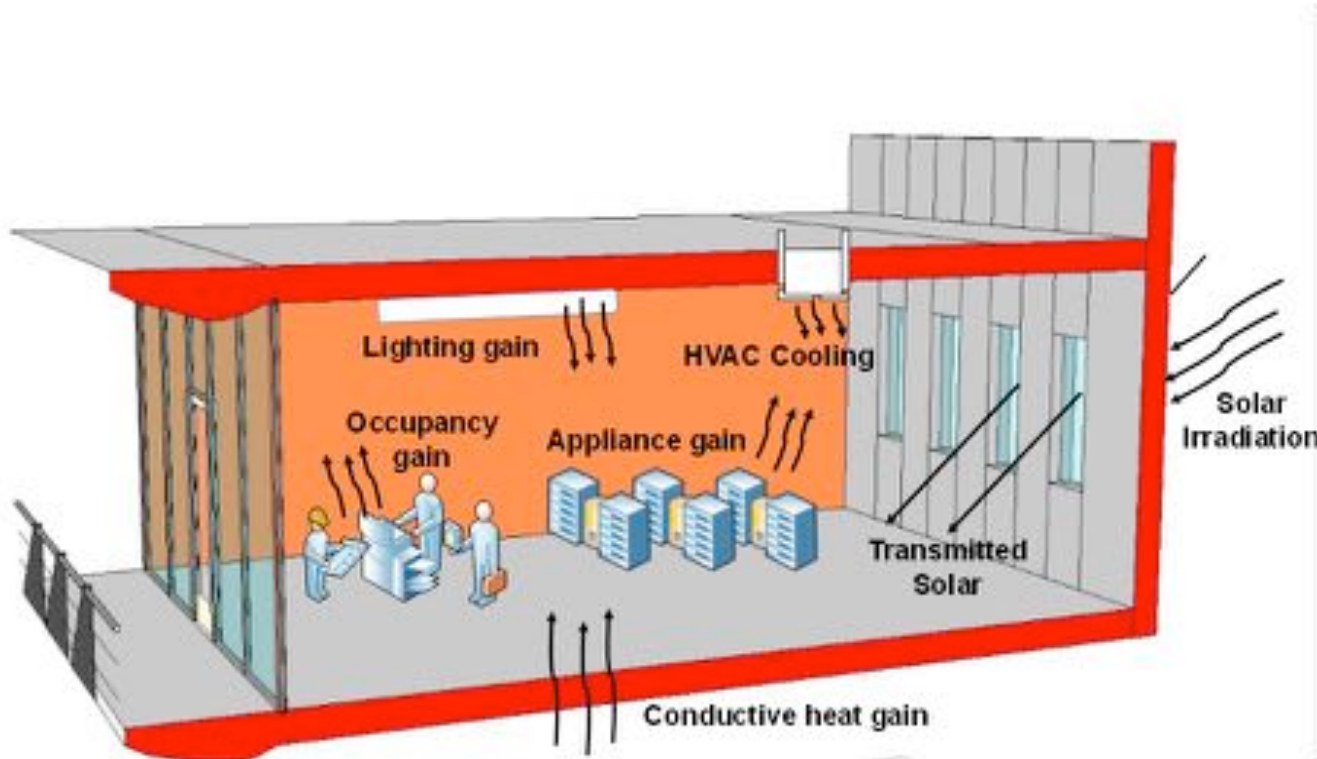

1. Solar Irradiance Q_{sol} :
2. Solar radiation transmitted through windows $Q_{sol,t}$:
3. Radiative internal heat gain Q_{rad} :
4. Convective heat gain Q_{conv} :
5. HVAC heat gain Q_{HVAC} or Q_{sens}
6. Boundary temperatures:

Heat gain from occupants

- Metabolic rate, adult female = Metabolic rate, adult male X 0.85
- Metabolic rate, children = Metabolic rate, adult male X 0.75

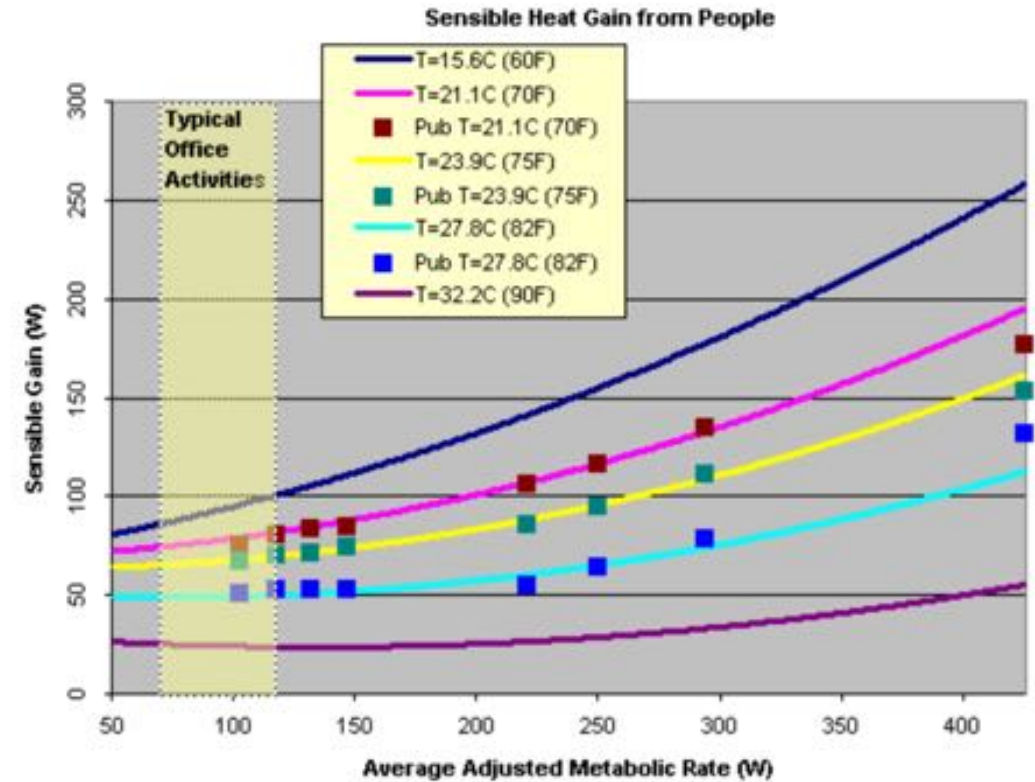

$$S = 6.461927 + .946892M + .0000255737M^2 + 7.139322T - .0627909TM + .0000589172TM^2 - .198550T^2 + .000940018T^2M - .00000149532T^2M^2$$

where

M = Metabolic Rate (W) T = Air Temperature (C)

Heat gain from occupants

No.	Degree of Activity	Typical Application	Total Heat Adjusted ^b		Sensible Heat		Latent Heat	
			Watts	Btu/h	Watts	Btu/h	Watts	Btu/h
1	Seated at rest	Theatre, movie	100	350	60	210	40	140
2	Seated, very light writing	Office, hotels, apartments	120	420	65	230	55	190
3	Seated, eating	Restaurant ^c	170	580	75	255	95	325
4	Seated, light work, typing	Offices, hotels, apartments	150	510	75	255	75	255
5	Standing, light work, or walking slowly	Retail Store, bank	185	640	90	315	95	325
6	light bench work	Factory	230	780	100	345	130	435
7	walking, 1.3 m/7s (3mph) light machine work	Factory	305	1040	100	345	205	695
8	Bowling ^d	Bowling alley	280	960	100	345	180	615
9	moderate dancing	Dance hall	375	1280	120	405	255	875
10	Heavy work, lifting Heavy machine work	Factory	470	1600	165	565	300	1035
11	Heavy work, athletics	Gymnasium	525	1800	185	635	340	1165

Single zone: Heat flows

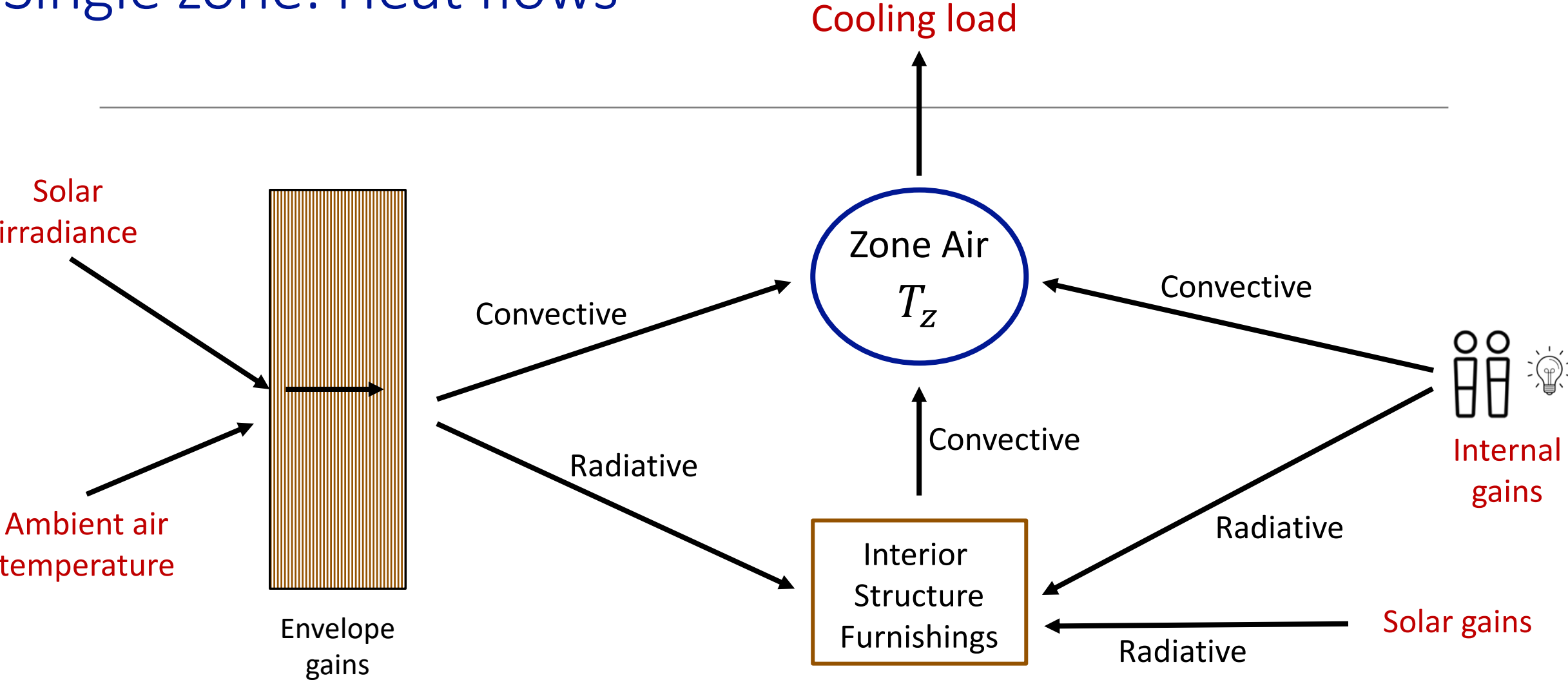

Modeling choices

1. Does every internal wall require its own RC branch ?
2. What about windows which maybe the same material bur face different directions ?
3. Do doors have thermal mass ?
4. How do you compute the total internal heat gain at any time ?
5. How are wall temperatures and incident solar irradiance measured ?

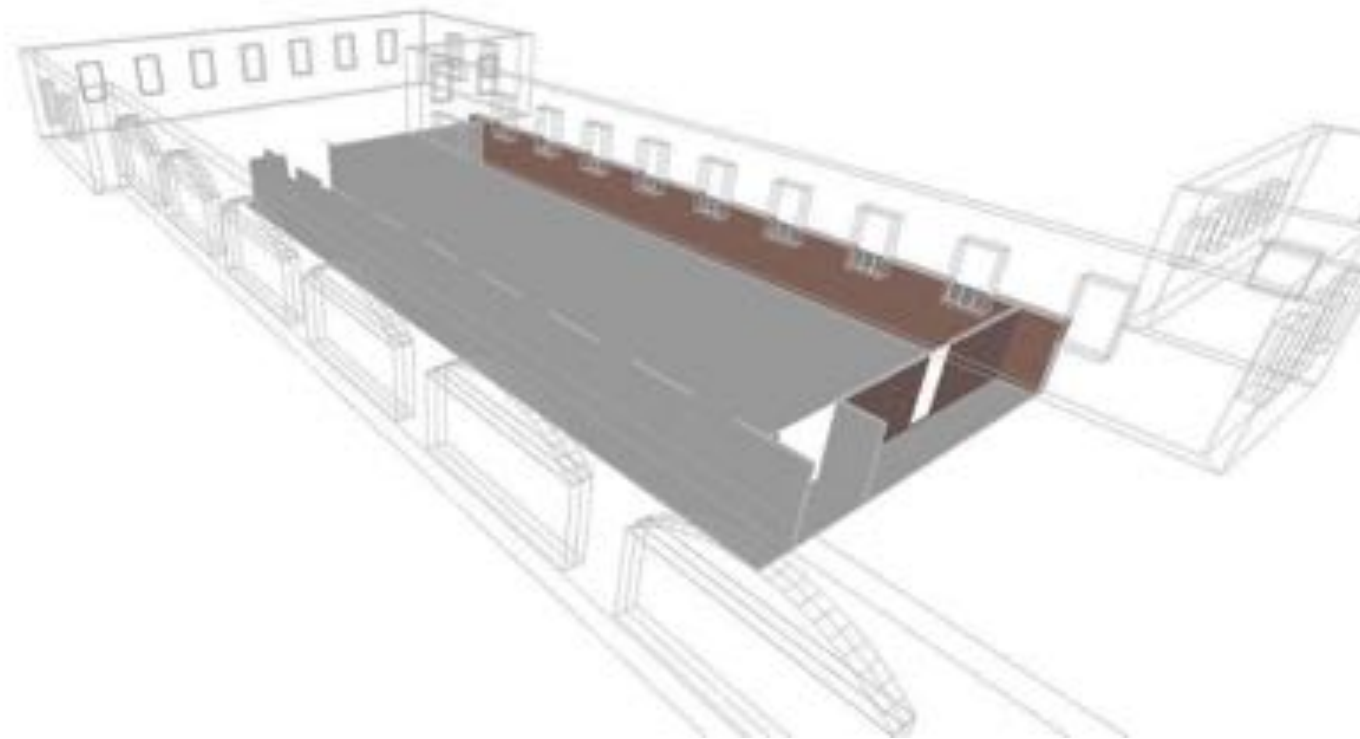

Measuring solar irradiance.



Pyranometer

Designed to measure the solar radiation flux density (W/m^2)

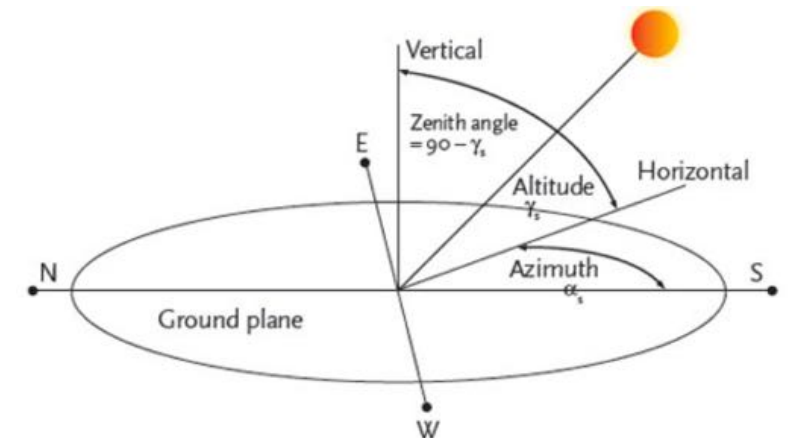

Multi-zone RC network

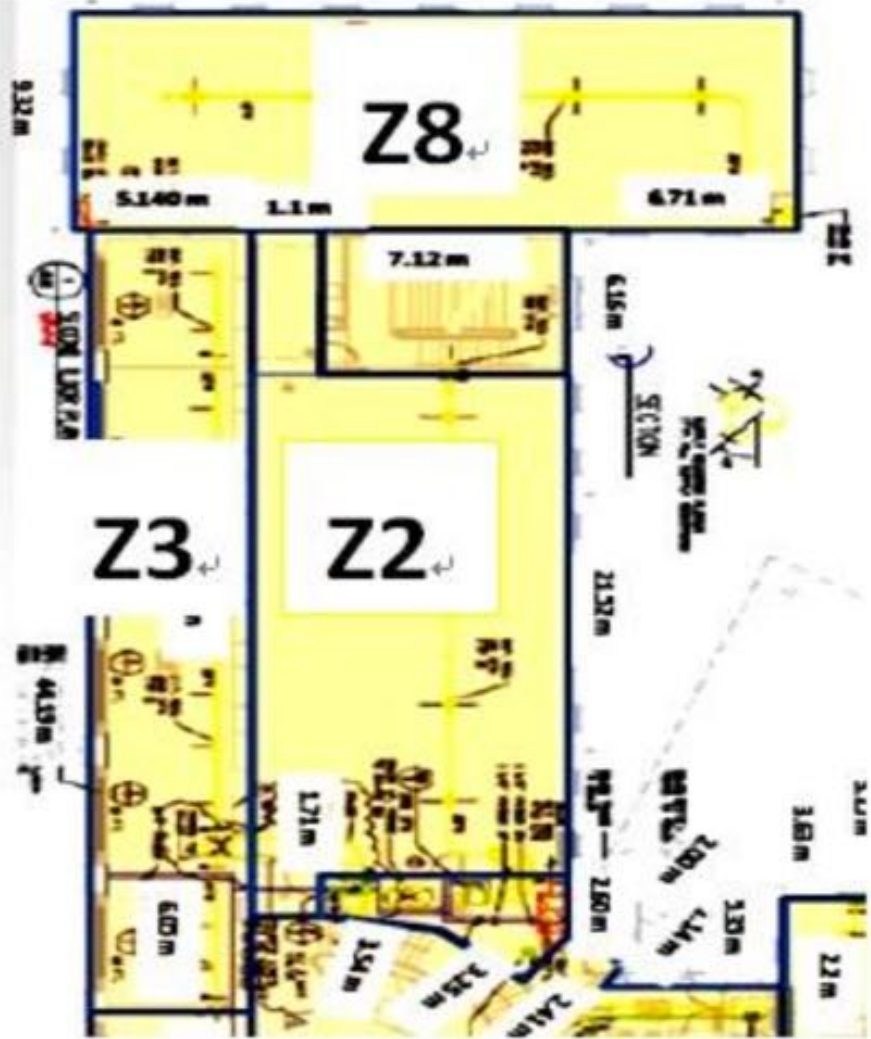

Multi-zone RC network

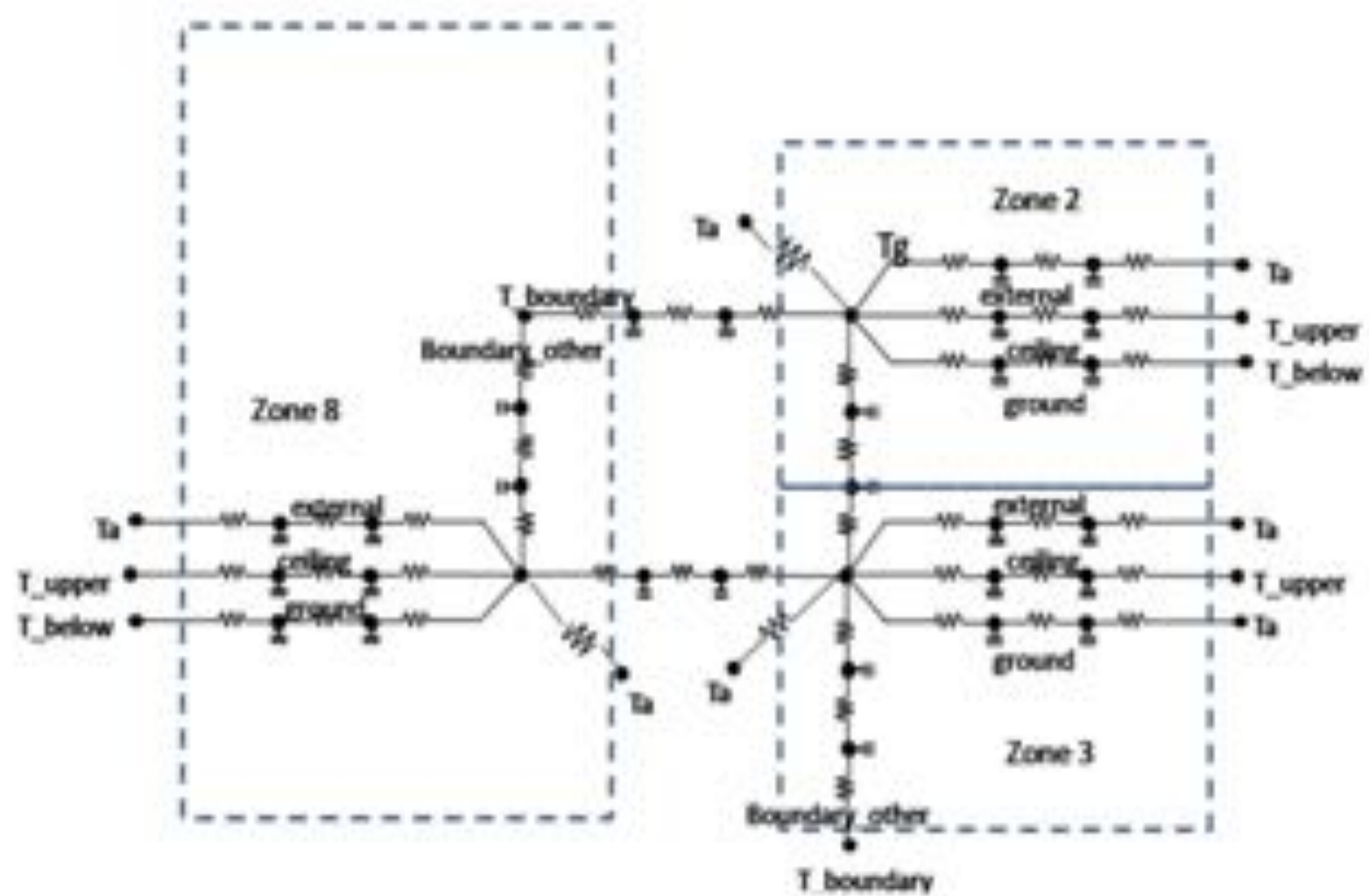

Alternate representation

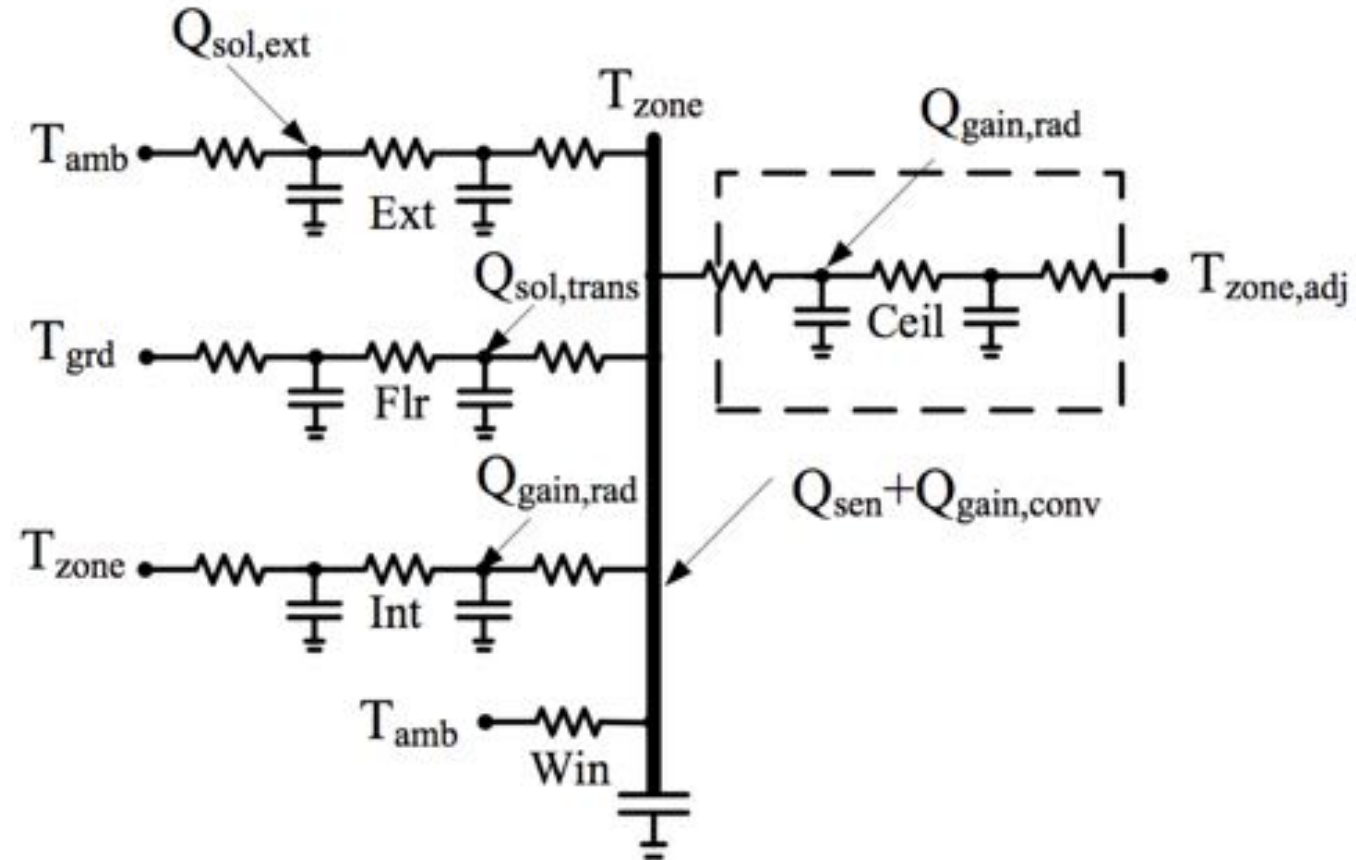

Alternate representation

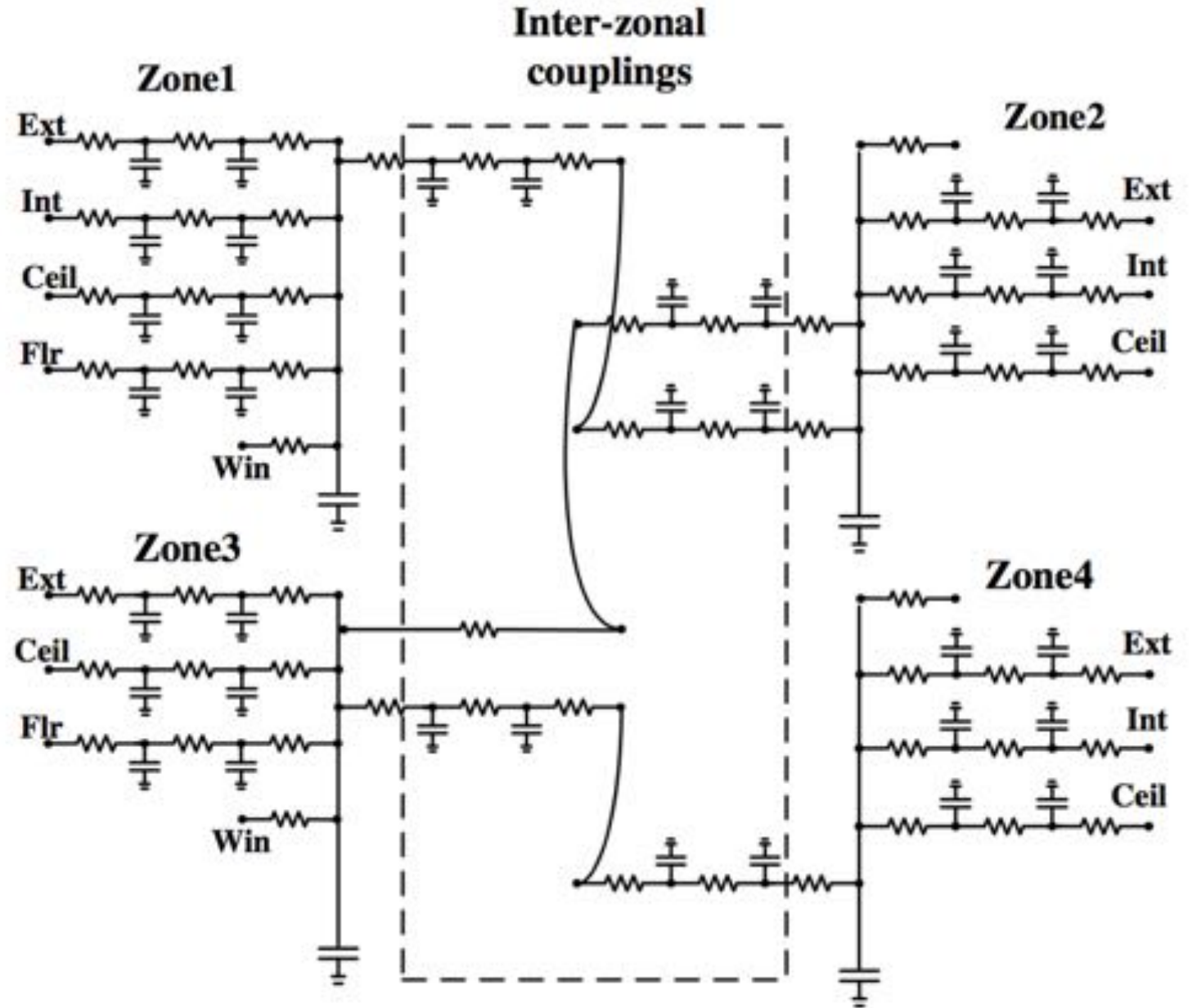

Energy CPS modeling assignments

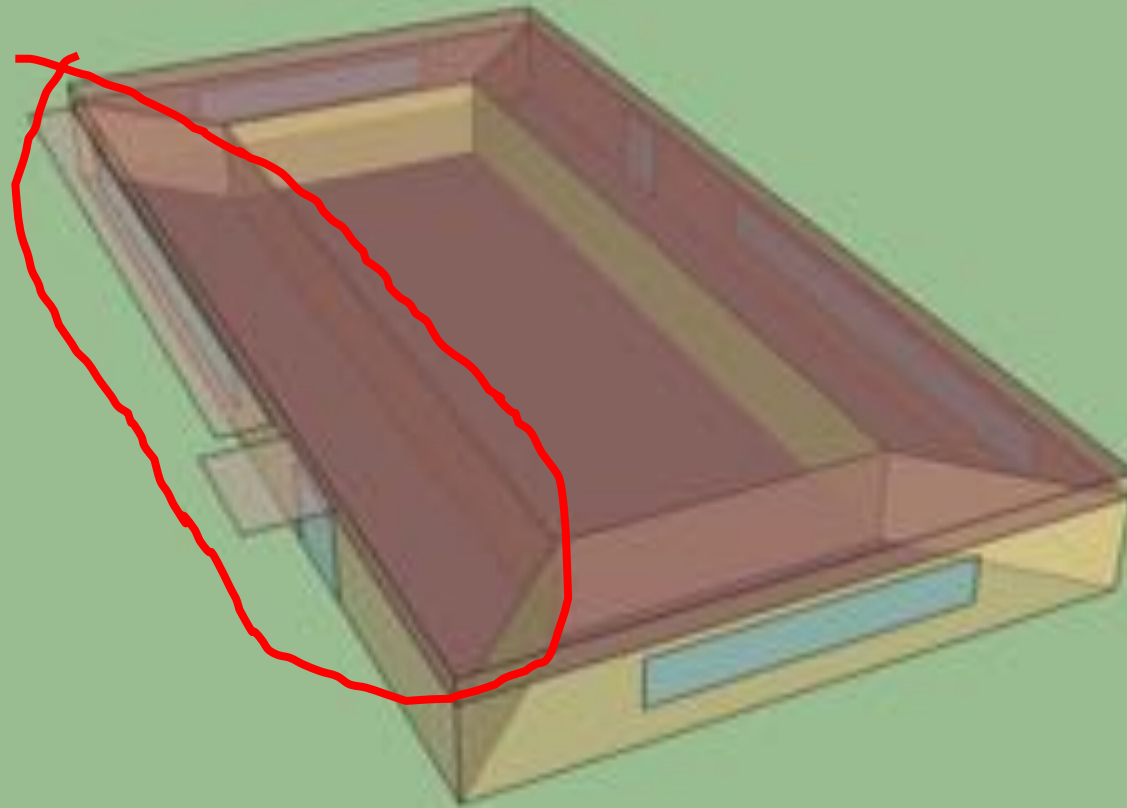

4 perimeter zones
1 interior zone

Module 1 modeling assignments

- **Assignment 2:**
 - Create the RC model structure.
- **Assignment 3:**
 - Nominal values of model parameters.
 - Model structure in Matlab
 - Training data set.
- **Assignment 4:**
 - Parameter tuning in Matlab.
 - Model validation.

Assignment 2

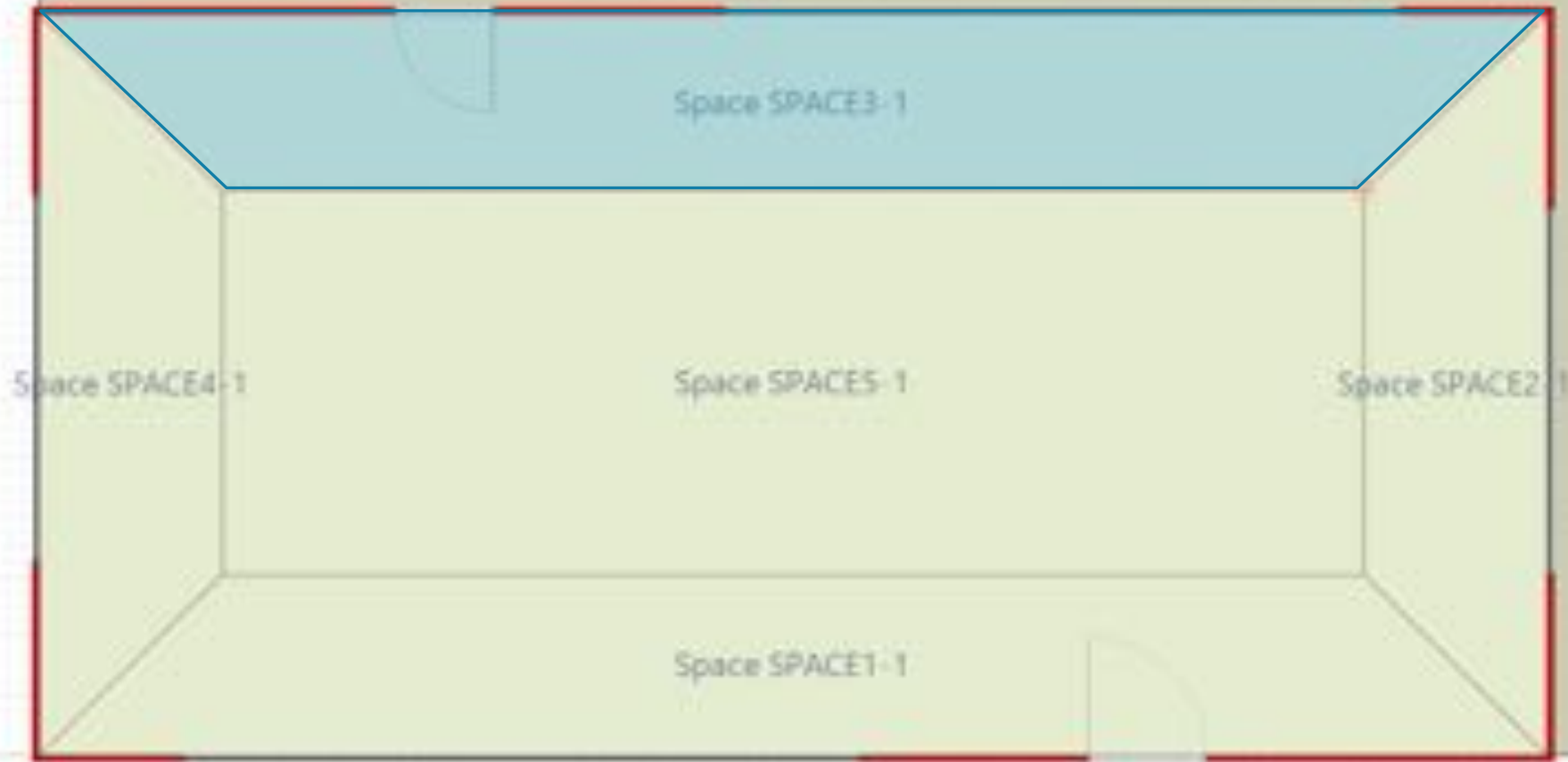

SPACE3-1: Inputs

1. Ground Temperature, T_g ($^{\circ}\text{C}$)
2. Outside ambient temperature, T_a ($^{\circ}\text{C}$)
3. Return air plenum temperature, T_p ($^{\circ}\text{C}$)
4. Total external solar heat gain, $Q_{sol,e}$ (W)
5. Total internal heat gain, Q_{gain} (W)
6. Total sensible cooling load, Q_{cool} (W)
7. Neighboring zone temperatures for SPACE2-1 T_2 , SPACE4-1 T_4 , SPACE5-1 T_5 ($^{\circ}\text{C}$)
8. SPACE3-1 zone temperature, T_z ($^{\circ}\text{C}$)

How to find the values of the parameters ?

$U_{\star o}$	convection coefficient between the wall and outside air
$U_{\star w}$	conduction coefficient of the wall
$U_{\star i}$	convection coefficient between the wall and zone air
U_{win}	conduction coefficient of the window
$C_{\star\star}$	thermal capacitance of the wall
C_z	thermal capacity of zone z_i

g : floor; e : external wall; c : ceiling; i : internal wall

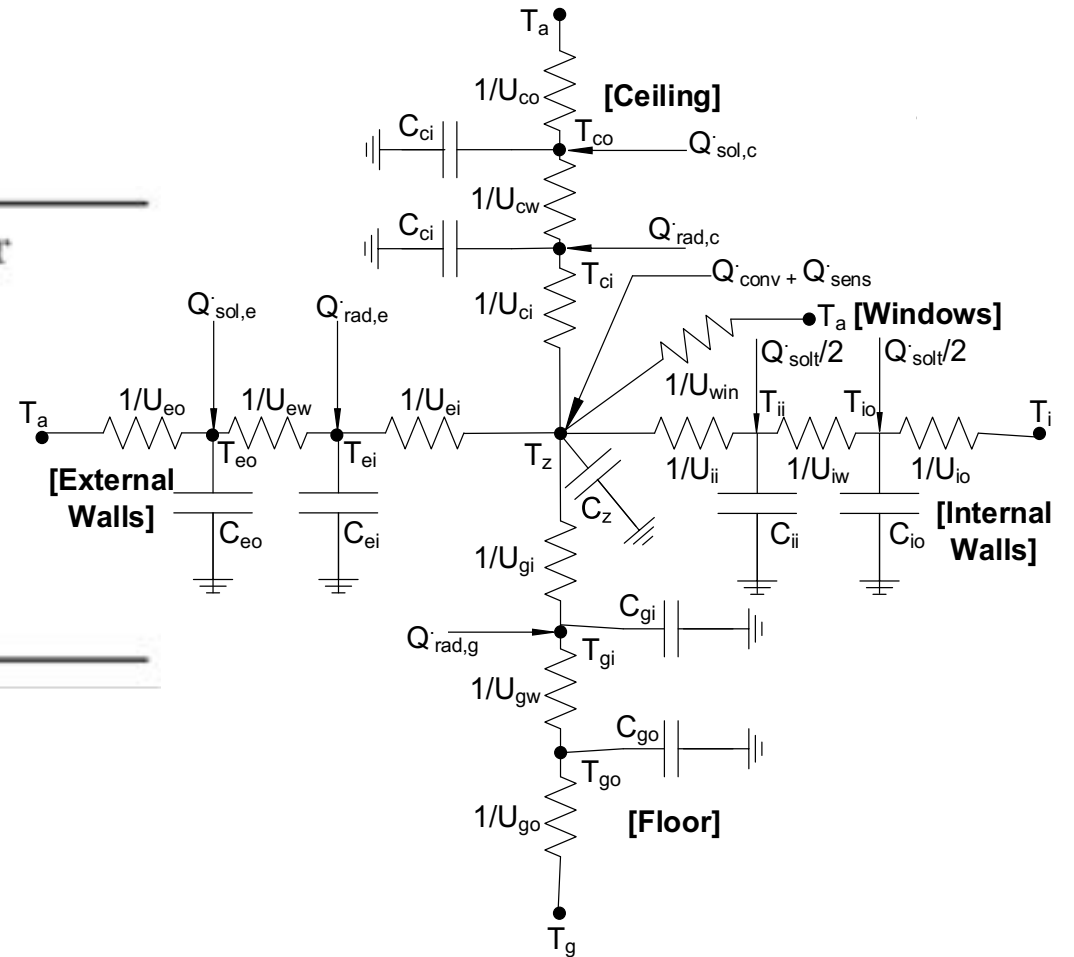

Next lecture:

- Intro to whole building simulation.
- White-box vs Grey-box
- EnergyPlus tutorial and demo
 - working with IDF files